

WM-PT Series

Paddle Wheel Flowmeters



This paddle wheel flowmeter, when used in conjunction with the appropriate adapter, can monitor flows in pipes ranging in size from 1/2" to 8". Paddle wheel flow meters are universally accepted as a means of measuring flow electronically. Wide range in flow rates, negligible headloss and good accuracy at a reasonable price, continue to make these meters popular. Easy removal for cleaning and repair permit the meters to be mounted in lines with moderate particulate levels.

This microprocessor-based flow meter utilizes a 21-digit liquid crystal display (LCD). Sturdy, compact, and water resistant design allows these meters to be mounted outdoors when shielded from direct sunlight. Isolated monitoring locations are also viable as power is supplied by a long, seven year, life battery.

The paddle wheel, spinning at a rate linearly proportional to the velocity of the flow, activates a switch once per revolution. The time it takes the paddle to rotate, divided into the diameter of the pipe, results in the flow rate. Flow rate variations are minimized by a microprocessor averaging process. The flow rate, a resettable and a non-resettable totalizer are simultaneously displayed.

Programming is accomplished using embossed buttons on the face. Programming consists of selecting the pipe size and schedule from a list; the default units are gallons/minute and gallons. For sizes not listed, the user can calibrate the meter using a factor derived from the inside diameter of the pipe. The meter can also be calibrated in Liters and cubic feet.

USAGE GUIDELINES

Paddle wheel type meters will only operate properly when the pipe is full and the flow rate is within the recommended range. Low accuracy and fouling problems are typical when pipes are too large and flow rates are not within the recommend range. Mounting configurations that allow air to become entrapped around the paddle will greatly affect the results. These meters will tolerate considerable sediment and debris.

WM-PT SERIES MODEL NUMBERING

Model No. **WM-PT-X-X-X-X**

Connection Type: _____
P = mounted on 13" Pipe
S = Insertion saddle mount

Pipe Schedule: _____
40 = 40
80 = 80

Pipe Size: _____
050 = 1/2"
075 = 3/4"
100 = 1"
150 = 1 1/2"
200 = 2"
300 = 3"
400 = 4"
600 = 6"
800 = 8"

Display/Output: _____
PT = Local Display (on meter)
RD = Remote Display (wall mount)

TEMPERATURE RANGE

Ambient:
0°F to 130°F (-20°C to 54°C)

Media:
40°F to 120°F (4.4°C to 49°C)

PRESSURE RATING

Body: 200 psi (13.8 bar) corresponding to standard Schedule 40 and 80 PVC pipe

MATERIALS

Paddle Wheel: PVC
Pipe: PVC
Pin: Stainless Steel
O-ring Seal: Buna-N
Electronics Enclosure: ABS

SPECIFICATIONS

Accuracy: +/- 1.5% full scale
Linearity: +/- 1.5%
Repeatability: +/- 1%

MOUNTING AND DISPLAY OPTIONS

There are 2 different meter installation options.

- Pipe Mount:** the meter comes installed centered on a 13" section of pipe. This style is simply inserted into your pipe using straight couplings. (*shown above*)
- Insertion Mount:** the meter comes with a "saddle" and 2 hose clamps that are used to attach the meter to an existing pipe. Once the saddle is attached to the pipe, a hole must be drilled in it for the paddle wheel to enter the pipe through. (*shown below*)



There are 2 different display options. Both display types come with either a saddle or pipe mount.

- Local:** the display is attached directly to the meter where the meter is installed.
- Remote:** the display is separate from the meter, and is connected to it with a wire.



Local Display

Remote Display

WM-PT Series

Paddle Wheel Flowmeters (Pipe Mount)

DIMENSIONS

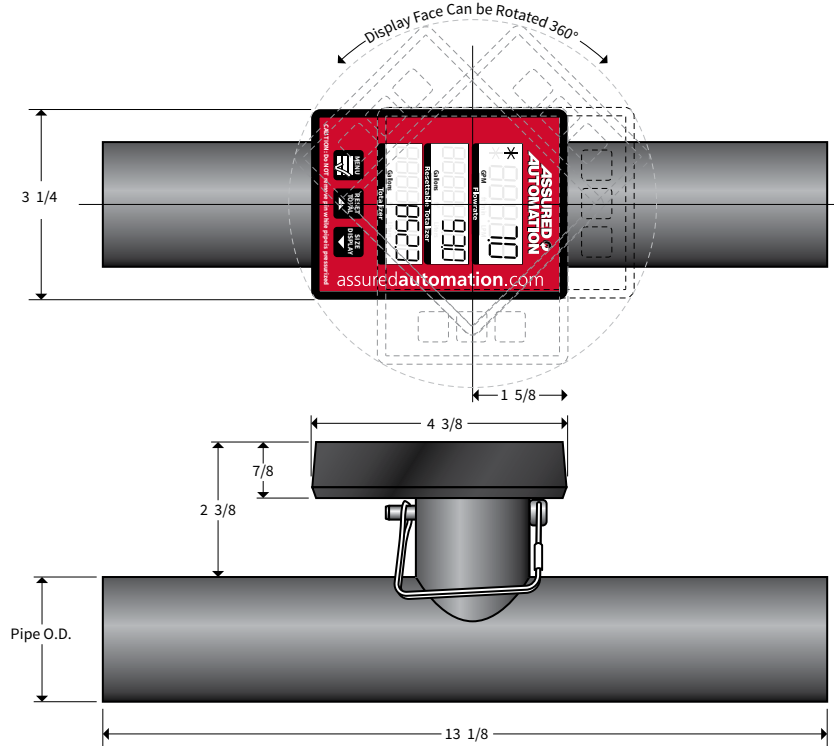

FLOW RANGES

| Pipe Size | PVC Schedule | Inner Diameter (in inches) | Flow Range | | | Styles |
|-----------|--------------|----------------------------|------------|-------------------|-----------------|--|
| | | | GPM | LPM | ft ³ | |
| 1/2" | 80 | 0.55 | 0.6 - 15 | 2.27 - 56.78 | 0.08 - 2.01 | ONLY Available in Pipe Mount |
| 3/4" | 80 | 0.74 | 1.5 - 30 | 5.68 - 113.56 | 0.20 - 4.01 | |
| 1" | 80 | 0.96 | 5 - 55 | 18.93 - 208.20 | 0.668 - 7.35 | |
| 1 1/2" | 40 | 1.61 | 10 - 125 | 37.85 - 473.18 | 1.337 - 16.71 | Available in Pipe Mount OR Insertion Mount |
| | 80 | 1.50 | | | | |
| 2" | 40 | 2.07 | 15 - 200 | 56.78 - 757.08 | 2.005 - 26.74 | |
| | 80 | 1.94 | | | | |
| 3" | 40 | 3.07 | 40 - 450 | 151.42 - 1703.44 | 5.35 - 60.16 | |
| | 80 | 2.90 | | | | |
| 4" | 40 | 4.03 | 60 - 800 | 227.12 - 3028.33 | 8.02 - 106.94 | |
| | 80 | 3.83 | | | | |
| 6" | 40 | 6.07 | 120 - 1800 | 454.25 - 6813.74 | 16.04 - 240.63 | ONLY Available in Insertion Mount |
| | 80 | 5.76 | | | | |
| 8" | 40 | 7.98 | 250 - 3200 | 946.35 - 12113.32 | 33.42 - 427.78 | |
| | 80 | 7.63 | | | | |