

STL Series

Resilient-Seated Lug Style Butterfly Valve



The STL is a resilient-seated 125/150, ductile iron, lug style butterfly valve available with either EPDM or BUNA-N seats and 316SS disc (other materials available upon request). It can be equipped with a manual handle or with pneumatic or electric actuators.

A full range of accessory items are available including limit switches, solenoid valves, positioners and manual override devices.

FEATURES

- Silicone free construction.
- Economy and high performance.
- One-piece body and self-centering disc.
- Seat facing acts as flange gasket.
- 3 shaft bushings support actuation.
- Shaft sealing against external leakage.
- Meets MSS SP-67 and API-609 specs.
- Complete line of accessories.

TYPICAL APPLICATIONS

- Water and waste effluent treatment plants.
- Paper, textiles and sugar industry.
- Construction industry, and drilling production.
- Heating, air conditioning, and cooling water circulation.
- Pneumatic conveyors, and vacuum applications.
- Compressed air, gas and desulphurization plants.
- Brewing, distilling, and chemical process industry.
- Transportation and dry bulk handling.
- Power industry.

ACTUATOR CONFIGURATIONS

- Electric.
- Pneumatic (spring return).
- Pneumatic (double acting).
- Manual handle.
- Manual handle with limit switch.

PRESSURE RANGE

29 inHg vacuum to 225 PSI:
2" to 12"
29 inHg vacuum to 160 PSI:
14" to 24"

TEMPERATURE RANGE

-22°F to 230°F (EPDM)
-4°F to 194°F (BUNA-N)

MATERIALS OF CONSTRUCTION

Seat:

EPDM or BUNA-N.

Disc:

316 stainless steel.

Body:

Epoxy coated ductile iron.

Lug Style Valve ▶

Installs between flanges. Bolts are threaded into tapped holes from each side of mounting flange.

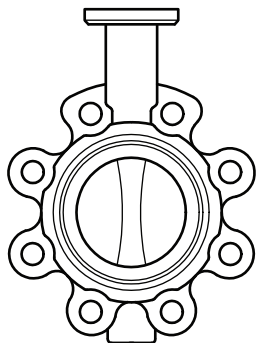

APPROVALS & CERTIFICATIONS

- ISO 9001 certified by LRQA, no. K981064.
- Canada registration no. CRN 0C0569.9C.
- CE/PED approved by Lloyds, no. RPS0160308/01.
- Products approved by South Africa SABS, no. 7222/145532/VH136.
- Designed to MSS SP-67, API 609.

PRESSURE TESTING

Body hydro: 24 bar (343 PSI)
Seat hydro: 17.6 bar (243 PSI)

DEAD END SERVICE

Downstream flange is recommended.
150 PSI: 2" to 12"
100 PSI: 14" to 24"

STL Series

Resilient-seated butterfly valve (Lug style)

CV FACTORS

Size	CV at Specified Disc Opening							
	20°	30°	40°	50°	60°	70°	80°	90°
1-12"	3	5	11	18	26	45	70	80
2"	8	9	18	28	55	72	110	135
2-1/2"	10	15	27	44	85	110	168	210
3"	15	23	39	65	130	165	250	310
4"	27	41	71	115	230	300	465	540
5"	58	86	150	245	480	610	980	1110
6"	96	140	245	400	785	1010	1615	1910
8"	165	245	410	685	1275	1715	2670	3185
10"	255	380	650	1130	2100	2700	4250	4900
12"	370	540	950	1570	3050	3950	5950	7350
14"	450	750	1300	2210	4080	5610	8078	11200
16"	640	900	1720	2790	5000	7650	10770	12900
18"	730	1250	2295	3700	7050	9180	13900	17500
20"	910	1595	2850	4630	8600	11500	17540	22400
24"	1250	2290	4000	6090	12500	16500	23590	28300

PARTS

- 1. Retainer Screw:** SS41 steel/plated.
- 2. Retainer Plate:** SS41 steel/plated.
- 3. Packing and O-Ring:** EPDM.
- 4. Upper Shaft:** SUS410 stainless steel.
- 5. Body:** Ductile iron (GGG40).
- 6. Seat:** BUNA-N (NBR) or EPDM.
- 7. Disc:** 316SS (CF8M) stainless steel.
- 8. Lower Shaft:** SUS410 stainless steel.
- 9. Plug:** SS41 stainless steel.

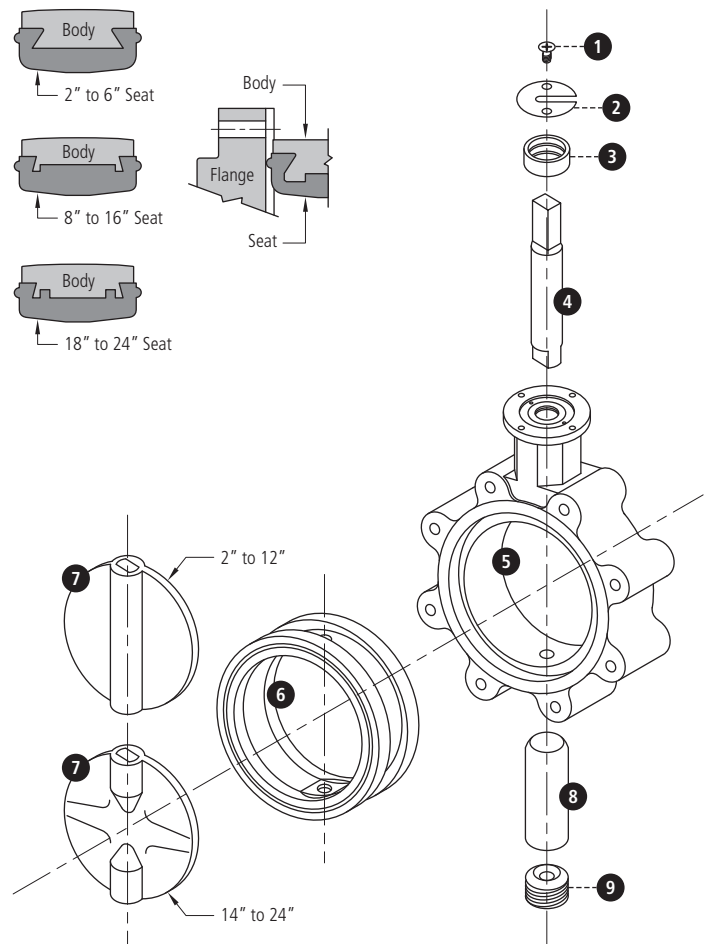

SEAT MATERIAL FEATURES

EPDM

- Ethylene propylene diene monomer rubber.
- Applications include water and steam, sea water, brine, esters, ketone, alkalis and caustic soda.
- Not recommended for hydrocarbons, oils or fats.

BUNA-N (NBR)

- Butadiene and acrylonitrile copolymer.
- Applications include hydrocarbons, natural gas, oils, fat, air and gasoline.
- Not recommended for solvents, benzene or xylol.

STLM / STLG Series 2" to 12" Sizes

Lug style butterfly valve with latch handle (STLM) or gear operator (STLG)
(Manual operation)

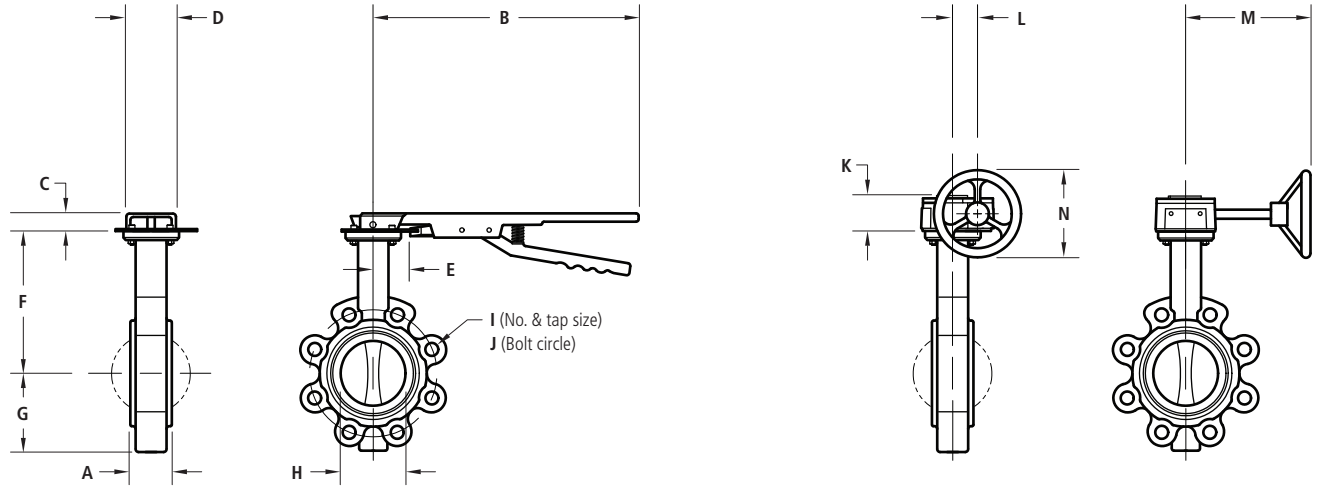

DIMENSIONS, WEIGHTS & SPECIFICATIONS

Size	A	B	C	D	E	F	G	H	I	J	Wt.* (lbs.)	Model No. (STLM)	
												EPDM	BUNA-N
2"	1.69	11.38	1.06	1.34	2.16	5.12	2.95	1.99	(4) 5/8"-11	4.75	14.0	HSTLESM	HSTLBSM
2-1/2"	1.81	11.38	1.06	1.34	2.16	5.39	3.15	2.61	(4) 5/8"-11	5.50	16.0	ISTLESM	ISTLBSM
3"	1.81	11.38	1.06	1.34	2.16	6.14	3.74	3.11	(4) 5/8"-11	6.00	18.0	JSTLESM	JSTLBSM
4"	2.05	11.38	1.06	1.34	2.16	6.69	4.33	3.92	(8) 5/8"-11	7.50	27.0	KSTLESM	KSTLBSM
5"	2.20	11.38	1.06	1.34	2.16	7.28	4.84	4.89	(8) 3/4"-10	8.50	32.3	LSTLESM	LSTLBSM
6"	2.20	11.38	1.06	1.34	2.16	7.99	5.63	5.89	(8) 3/4"-10	9.50	42.8	MSTLESM	MSTLBSM
8"	2.36	17.84	1.02	1.77	1.65	9.37	6.61	7.70	(8) 3/4"-10	11.75	59.8	NSTLESM	NSTLBSM
10"	2.68	17.84	1.02	1.77	2.08	10.63	7.99	9.72	(12) 7/8"-9	14.25	91.9	OSTLESM	OSTLBSM
12"	3.07	17.84	1.02	1.77	2.08	12.20	9.53	11.63	(12) 7/8"-9	17.00	165.9	PSTLESM	PSTLBSM

* Weight is for valve only.

STL VALVE FEATURES

- Silicone free lug style butterfly valve.
- Ductile iron body.
- 316 stainless steel disc and 410 stainless steel stem.
- EPDM and BUNA-N seats.
- Mounting pad for direct mount actuator per ISO 5211.
- Pressure range: 29 inHg vacuum to 225 PSI.

LEVER HANDLE FEATURES

- 10 position latch plate.

ADDITIONAL DIMENSIONS & SPECIFICATIONS

Size	K	L	M	N	Gear Operator	Model No. (STLG)	
						EPDM	BUNA-N
2"	2.84	1.77	6.62	5.79	24:1	HSTLESG	HSTLBSG
2-1/2"	2.84	1.77	6.62	5.79	24:1	ISTLESG	ISTLBSG
3"	2.84	1.77	6.62	5.79	24:1	JSTLESG	JSTLBSG
4"	2.84	1.77	6.62	5.79	24:1	KSTLESG	KSTLBSG
5"	2.84	1.77	6.62	5.79	24:1	LSTLESG	LSTLBSG
6"	2.84	1.77	6.62	5.79	24:1	MSTLESG	MSTLBSG
8"	3.31	2.60	7.53	11.82	30:1	NSTLESG	NSTLBSG
10"	3.31	2.60	7.53	11.82	30:1	OSTLESG	OSTLBSG
12"	3.31	2.60	10.54	11.82	30:1	PSTLESG	PSTLBSG

STLG Series 14" to 24" Sizes

Lug style butterfly valve with gear operator
(Manual operation)

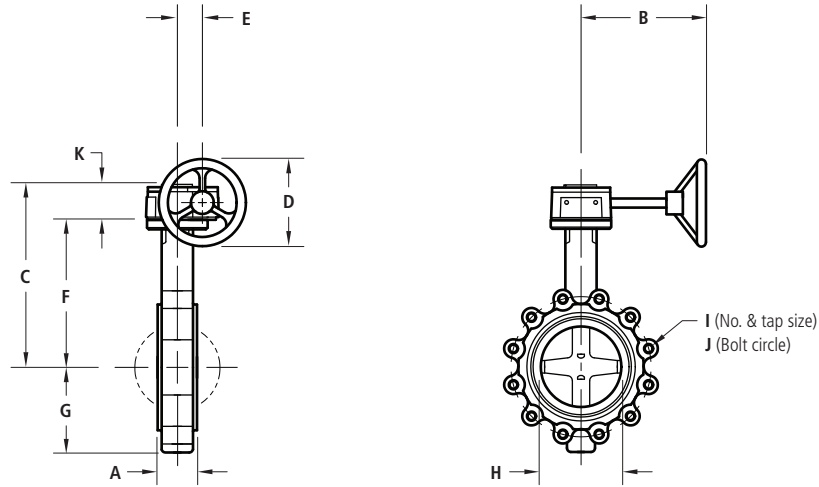

DIMENSIONS, WEIGHTS & SPECIFICATIONS

Size	A	B	C	D	E	F	G	H	I	J	K	Gear Operator	Wt.* (lbs.)	Model No.	
														EPDM	BUNA-N
14"	3.07	10.54	17.09	11.82	3.05	13.60	10.41	12.99	(12) 1"-8	18.75	3.49	50:1	143	QSTLESG	QSTLBSG
16"	4.02	10.54	17.25	11.82	3.05	13.76	11.75	14.92	(16) 1"-8	21.25	3.49	50:1	243	RSTLESG	RSTLBSG
18"	4.49	10.54	19.24	15.56	3.05	15.75	13.78	17.20	(16) 1.12"-7	22.75	3.49	50:1	310	SSTLESG	SSTLBSG
20"	5.00	12.21	21.65	15.56	5.32	17.32	14.96	19.29	(20) 1.12"-7	25.00	4.33	80:1	512	TSTLESG	TSTLBSG
24"	6.06	12.21	24.41	15.56	5.32	20.08	17.32	22.62	(20) 1.25"-7	29.50	4.33	80:1	686	USTLESG	USTLBSG

*Weight is for valve only.

STL VALVE FEATURES

- Silicone free lug style butterfly valve.
- Ductile iron body.
- 316 stainless steel disc and 410 stainless steel stem.
- EPDM and BUNA-N seats.
- Mounting pad for direct mount actuator per ISO 5211.
- Pressure range: 29 inHg vacuum to 160 PSI.

STLOS R Series

Lug style butterfly valve with spring return pneumatic actuator

(Actuators are sized for 150 PSI liquid media line pressure, contact factory for higher line pressure ratings)

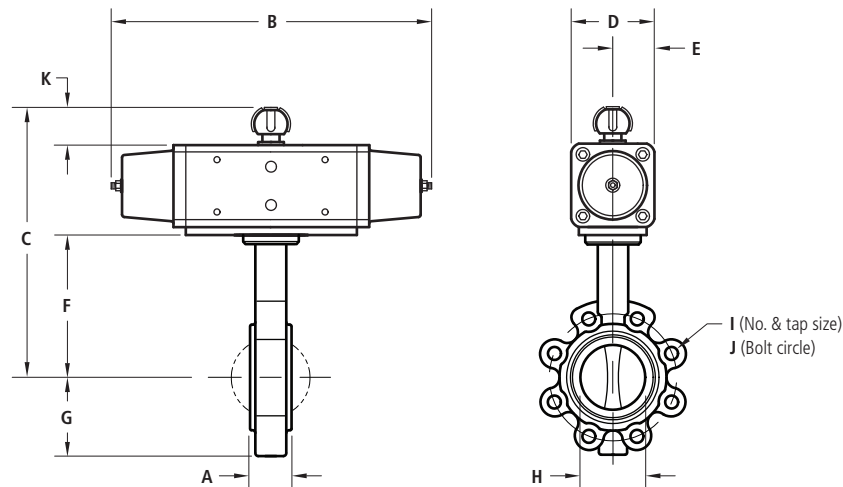

DIMENSIONS, WEIGHTS & SPECIFICATIONS

Size	A	B	C	D	E	F	G	H	I	J	K	Actuator	Wt. (lbs.)	Model No.	
														EPDM	BUNA-N
80 psig Minimum Actuator Air Supply = 85															
2"	1.69	11.58	8.96	2.83	1.41	5.12	2.95	1.99	(4) 5/8"-11	4.75	.79	PS045	15.3	HSTLES08S	HSTLBS08S
2-1/2"	1.81	11.58	9.23	2.83	1.41	5.39	3.15	2.61	(4) 5/8"-11	5.50	.79	PS045	17.3	ISTLES08S	ISTLBS08S
3"	1.81	11.58	9.98	2.83	1.41	6.14	3.74	3.11	(4) 5/8"-11	6.00	.79	PS045	19.3	JSTLES08S	JSTLBS08S
4"	2.05	11.58	10.53	2.83	1.41	6.69	4.33	3.92	(8) 5/8"-11	7.50	.79	PS045	28.3	KSTLES08S	KSTLBS08S
5"	2.20	12.60	11.84	3.15	1.57	7.28	4.84	4.89	(8) 3/4"-10	8.50	1.18	PS060	34.7	LSTLES08S	LSTLBS08S
6"	2.20	14.06	12.95	3.54	1.77	7.99	5.63	5.89	(8) 3/4"-10	9.50	1.18	PS090	46.1	MSTLES08S	MSTLBS08S
8"	2.36	17.18	15.19	4.41	2.20	9.37	6.61	7.70	(8) 3/4"-10	11.75	1.18	PS180	67.7	NSTLES08S	NSTLBS08S
10"	2.68	22.28	17.64	5.37	2.54	10.63	7.99	9.72	(12) 7/8"-9	14.25	1.18	PS360	104.0	OSTLES08S	OSTLBS08S
12"	3.07	22.28	19.21	5.37	2.54	12.20	9.53	11.63	(12) 7/8"-9	17.00	1.18	PS360	178.0	PSTLES08S	PSTLBS08S
60 psig Minimum Actuator Air Supply = 65															
2"	1.69	14.06	10.08	3.54	1.77	5.12	2.95	1.99	(4) 5/8"-11	4.75	1.18	PS090-60	20.1	HSTLES06S	HSTLBS06S
2-1/2"	1.81	14.06	10.35	3.54	1.77	5.39	3.15	2.61	(4) 5/8"-11	5.50	1.18	PS090-60	22.1	ISTLES06S	ISTLBS06S
3"	1.81	14.06	11.01	3.54	1.77	6.14	3.74	3.11	(4) 5/8"-11	6.00	1.18	PS090-60	24.1	JSTLES06S	JSTLBS06S
4"	2.05	14.06	11.65	3.54	1.77	6.69	4.33	3.92	(8) 5/8"-11	7.50	1.18	PS090-60	33.1	KSTLES06S	KSTLBS06S
5"	2.20	17.18	13.10	4.41	2.20	7.28	4.84	4.89	(8) 3/4"-10	8.50	1.18	PS180-60	47.7	LSTLES06S	LSTLBS06S
6"	2.20	17.18	13.81	4.41	2.20	7.99	5.63	5.89	(8) 3/4"-10	9.50	1.18	PS180-60	56.7	MSTLES06S	MSTLBS06S
8"	2.36	22.28	16.38	5.37	2.54	9.37	6.61	7.70	(8) 3/4"-10	11.75	1.18	PS360-60	82.0	NSTLES06S	NSTLBS06S
10"	2.68	24.00	17.84	5.71	2.71	10.63	7.99	9.72	(12) 7/8"-9	14.25	1.18	PS480-60	111.2	OSTLES06S	OSTLBS06S
12"	3.07	28.05	20.71	6.52	3.11	12.20	9.53	11.63	(12) 7/8"-9	17.00	1.18	PS720-60	218.7	PSTLES06S	PSTLBS06S

STL VALVE FEATURES

- Silicone free lug style butterfly valve.
- Ductile iron body.
- 316 stainless steel disc and 410 stainless steel stem.
- EPDM and BUNA-N seats.
- Mounting pad for direct mount actuator per ISO 5211.
- Pressure range: 29 inHg vacuum to 225 PSI.

PNEUMATIC ACTUATOR FEATURES

- O Series spring return pneumatic actuator.
- Corrosion resistant coating.
- NAMUR solenoid mounting pad, ISO 5211 mounting standard.
- Visual position indicators.
- High duty cycle, permanent lubrication.
- Temperature range: -4°F to 175°F.

STLODA Series

Lug style butterfly valve with double acting pneumatic actuator

(Actuators are sized for 150 PSI liquid media line pressure, contact factory for higher line pressure ratings)

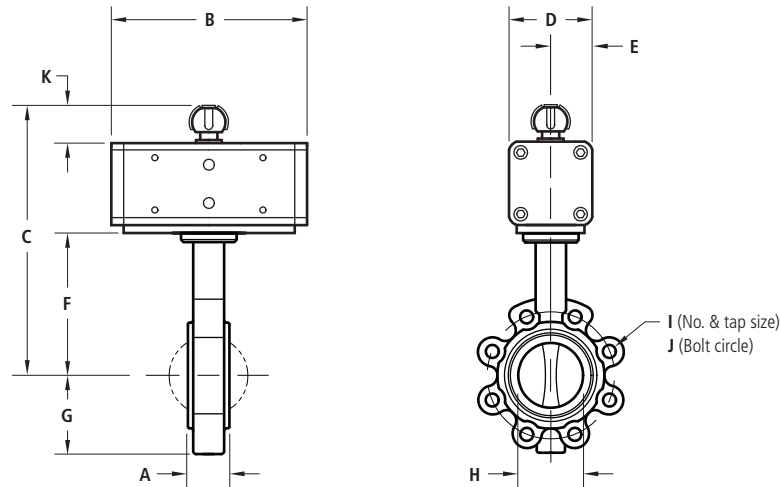

DIMENSIONS, WEIGHTS & SPECIFICATIONS

Size	A	B	C	D	E	F	G	H	I	J	K	Actuator	Wt. (lbs.)	Model No.	
														EPDM	BUNA-N
80 psig Minimum Actuator Air Supply = 8D															
2"	1.69	7.09	8.96	2.83	1.41	5.12	2.95	1.99	(4) 5/8"-11	4.75	.79	PD090	14.1	HSTLES08D	HSTLBS08D
2-1/2"	1.81	7.09	9.23	2.83	1.41	5.39	3.15	2.61	(4) 5/8"-11	5.50	.79	PD090	16.1	ISTLES08D	ISTLBS08D
3"	1.81	7.09	9.98	2.83	1.41	6.14	3.74	3.11	(4) 5/8"-11	6.00	.79	PD090	18.1	JSTLES08D	JSTLBS08D
4"	2.05	7.09	10.53	2.83	1.41	6.69	4.33	3.92	(8) 5/8"-11	7.50	.79	PD090	27.1	KSTLES08D	KSTLBS08D
5"	2.20	7.83	11.12	2.83	1.41	7.28	4.84	4.89	(8) 3/4"-10	8.50	.79	PD090	31.1	LSTLES08D	LSTLBS08D
6"	2.20	8.70	12.95	3.54	1.77	7.99	5.63	5.89	(8) 3/4"-10	9.50	1.18	PD0180	43.5	MSTLES08D	MSTLBS08D
8"	2.36	11.14	14.33	3.54	1.77	9.37	6.61	7.70	(8) 3/4"-10	11.75	1.18	PD0180	54.5	NSTLES08D	NSTLBS08D
10"	2.68	12.01	16.45	4.41	2.20	10.63	7.99	9.72	(12) 7/8"-9	14.25	1.18	PD0360	84.9	OSTLES08D	OSTLBS08D
12"	3.07	12.01	18.02	4.41	2.20	12.20	9.53	11.63	(12) 7/8"-9	17.00	1.18	PD0360	158.9	PSTLES08D	PSTLBS08D
60 psig Minimum Actuator Air Supply = 6D															
2"	1.69	7.09	8.96	2.83	1.41	5.12	2.95	1.99	(4) 5/8"-11	4.75	.79	PD090	14.1	HSTLES06D	HSTLBS06D
2-1/2"	1.81	7.09	9.23	2.83	1.41	5.39	3.15	2.61	(4) 5/8"-11	5.50	.79	PD090	16.1	ISTLES06D	ISTLBS06D
3"	1.81	7.09	9.98	2.83	1.41	6.14	3.74	3.11	(4) 5/8"-11	6.00	.79	PD090	18.1	JSTLES06D	JSTLBS06D
4"	2.05	7.09	10.53	2.83	1.41	6.69	4.33	3.92	(8) 5/8"-11	7.50	.79	PD090	27.1	KSTLES06D	KSTLBS06D
5"	2.20	8.70	11.12	2.83	1.41	7.28	4.84	4.89	(8) 3/4"-10	8.50	.79	PD090	31.1	LSTLES06D	LSTLBS06D
6"	2.20	11.14	12.95	3.54	1.77	7.99	5.63	5.89	(8) 3/4"-10	9.50	1.18	PD0180	43.5	MSTLES06D	MSTLBS06D
8"	2.36	11.14	14.33	3.54	1.77	9.37	6.61	7.70	(8) 3/4"-10	11.75	1.18	PD0180	54.5	NSTLES06D	NSTLBS06D
10"	2.68	12.01	16.93	4.81	2.27	10.63	7.99	9.72	(12) 7/8"-9	14.25	1.18	PD0480	57.5	OSTLES06D	OSTLBS06D
12"	3.07	15.24	18.50	4.81	2.27	12.20	9.53	11.63	(12) 7/8"-9	17.00	1.18	PD0480	161.5	PSTLES06D	PSTLBS06D

STL VALVE FEATURES

- Silicone free lug style butterfly valve.
- Ductile iron body.
- 316 stainless steel disc and 410 stainless steel stem.
- EPDM and BUNA-N seats.
- Mounting pad for direct mount actuator per ISO 5211.
- Pressure range: 29 inHg vacuum to 225 PSI.

PNEUMATIC ACTUATOR FEATURES

- O Series double acting pneumatic actuator.
- Corrosion resistant coating.
- NAMUR solenoid mounting pad, ISO 5211 mounting standard.
- Visual position indicators.
- High duty cycle, permanent lubrication.
- Temperature range: -4°F to 175°F.

STLK4 Series 2" to 12" Sizes

Lug style butterfly valve with electric actuator

(Actuators are sized for 150 PSI liquid media line pressure, contact factory for higher line pressure ratings)

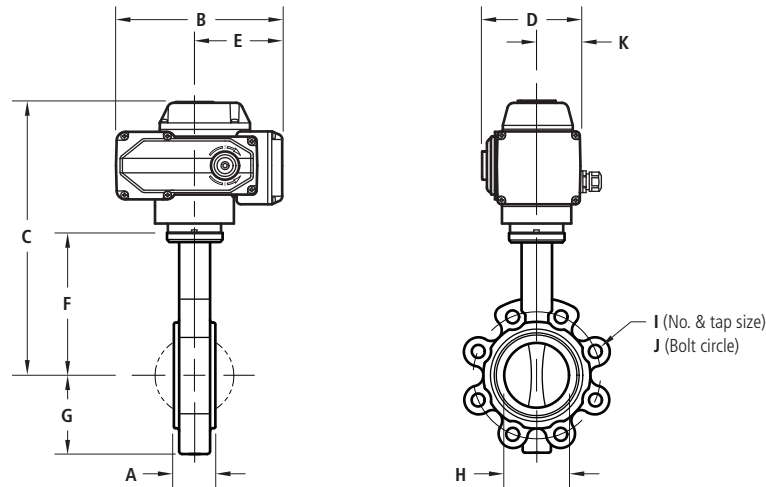

DIMENSIONS, WEIGHTS & SPECIFICATIONS

Size	A	B	C	D	E	F	G	H	I	J	K	Actuator	Wt. (lbs.)	Model No.	
														EPDM	BUNA-N
2"	1.69	8.17	11.56	4.82	4.33	5.12	2.95	1.99	(4) 5/8"-11	4.75	2.14	UNIC10	20.0	HSTLESK4	HSTLBSK4
2-1/2"	1.81	8.17	11.83	4.82	4.33	5.39	3.15	2.61	(4) 5/8"-11	5.50	2.14	UNIC10	22.0	ISTLESK4	ISTLBSK4
3"	1.81	8.17	12.58	4.82	4.33	6.14	3.74	3.11	(4) 5/8"-11	6.00	2.14	UNIC10	24.0	JSTLESK4	JSTLBSK4
4"	2.05	8.17	13.13	4.82	4.33	6.69	4.33	3.92	(8) 5/8"-11	7.50	2.14	UNIC10	33.0	KSTLESK4	KSTLBSK4
5"	2.20	8.17	13.72	4.82	4.33	7.28	4.84	4.89	(8) 3/4"-10	8.50	2.14	UNIC10	37.0	LSTLESK4	LSTLBSK4
6"	2.20	8.17	14.43	4.82	4.33	7.99	5.63	5.89	(8) 3/4"-10	9.50	2.14	UNIC10	46.0	MSTLESK4	MSTLBSK4
8"	2.36	10.10	16.67	6.16	5.25	9.37	6.61	7.70	(8) 3/4"-10	11.75	2.46	UNIC20	65.0	NSTLESK4	NSTLBSK4
10"	2.68	15.00	19.84	9.53	7.85	10.63	7.99	9.72	(12) 7/8"-9	14.25	4.13	UNIC60	115.2	OSTLESK4	OSTLBSK4
12"	3.07	15.00	21.41	9.53	7.85	12.20	9.53	11.63	(12) 7/8"-9	17.00	4.13	UNIC60	189.2	PSTLESK4	PSTLBSK4

STL VALVE FEATURES

- Silicone free lug style butterfly valve.
- Ductile iron body.
- 316 stainless steel disc and 410 stainless steel stem.
- EPDM and BUNA-N seats.
- Mounting pad for direct mount actuator per ISO 5211.
- Pressure range: 29 inHg vacuum to 225 PSI.

ELECTRIC ACTUATOR FEATURES

- K Series electric actuator.
- Actuator speed: 25 sec.
- Most voltages available.
- Quarter turn: 0-90° rotation.
- NEMA 4/4X certified by UL labs.
- ISO 5211 mounting standard.
- Visual position indicators.
- Self-locking drive train.
- Mounts in any direction.
- 1/2" NPT conduit connection.
- CSA-NRTL/C and CE certified.
- Temperature range: 0°F to 160°F.

STLESR Series 2" to 12" Sizes

Lug style butterfly valve with spring return pneumatic actuator

(Actuators are sized for 150 PSI liquid media line pressure, contact factory for higher line pressure ratings)

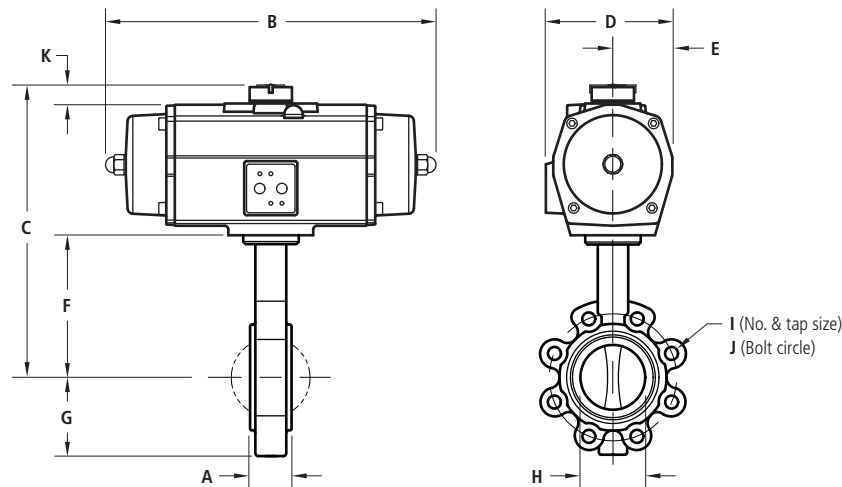

DIMENSIONS, WEIGHTS & SPECIFICATIONS

Size	A	B	C	D	E	F	G	H	I	J	K	Actuator	Wt. (lbs.)	Model No.	
														EPDM	BUNA-N
80 psig Minimum Actuator Air Supply = 85															
2"	1.69	9.80	10.04	4.19	1.93	5.12	2.95	1.99	(4) 5/8"-11	4.75	.79	ES65-5	17.9	HSTLESE8S	HSTLBSE8S
2-1/2"	1.81	9.80	10.31	4.19	1.93	5.39	3.15	2.61	(4) 5/8"-11	5.50	.79	ES65-5	19.9	ISTLESE8S	ISTLBSE8S
3"	1.81	9.80	11.06	4.19	1.93	6.14	3.74	3.11	(4) 5/8"-11	6.00	.79	ES65-5	21.9	JSTLESE8S	JSTLBSE8S
4"	2.05	9.80	11.51	4.19	1.93	6.69	4.33	3.92	(8) 5/8"-11	7.50	.79	ES65-5	30.9	KSTLESE8S	KSTLBSE8S
5"	2.20	14.17	13.70	5.39	2.52	7.28	4.84	4.89	(8) 3/4"-10	8.50	.79	ES200-5	47.1	LSTLESE8S	LSTLBSE8S
6"	2.20	14.17	14.41	5.39	2.52	7.99	5.63	5.89	(8) 3/4"-10	9.50	.79	ES200-5	56.1	MSTLESE8S	MSTLBSE8S
8"	2.36	15.24	17.29	7.12	3.41	9.37	6.61	7.70	(8) 3/4"-10	11.75	.79	ES350-5	84.3	NSTLESE8S	NSTLBSE8S
10"	2.68	18.78	20.47	8.52	4.08	10.63	7.99	9.72	(12) 7/8"-9	14.25	1.18	ES600-5	129.8	OSTLESE8S	OSTLBSE8S
12"	3.07	20.35	23.58	9.51	4.54	12.20	9.53	11.63	(12) 7/8"-9	17.00	1.18	ES950-5	228.1	PSTLESE8S	PSTLBSE8S
60 psig Minimum Actuator Air Supply = 65															
2"	1.69	10.51	10.56	4.60	2.12	5.12	2.95	1.99	(4) 5/8"-11	4.75	.79	ES100-4	20.1	HSTLESE6S	HSTLBSE6S
2-1/2"	1.81	10.51	10.83	4.60	2.12	5.39	3.15	2.61	(4) 5/8"-11	5.50	.79	ES100-4	22.1	ISTLESE6S	ISTLBSE6S
3"	1.81	10.51	11.58	4.60	2.12	6.14	3.74	3.11	(4) 5/8"-11	6.00	.79	ES100-4	24.1	JSTLESE6S	JSTLBSE6S
4"	2.05	10.51	12.13	4.60	2.12	6.69	4.33	3.92	(8) 5/8"-11	7.50	.79	ES100-4	33.1	KSTLESE6S	KSTLBSE6S
5"	2.20	14.17	13.70	5.39	2.52	7.28	4.84	4.89	(8) 3/4"-10	8.50	.79	ES200-4	47.1	LSTLESE6S	LSTLBSE6S
6"	2.20	14.17	14.41	5.39	2.52	7.99	5.63	5.89	(8) 3/4"-10	9.50	.79	ES200-4	56.1	MSTLESE6S	MSTLBSE6S
8"	2.36	15.24	17.29	7.12	3.41	9.37	6.61	7.70	(8) 3/4"-10	11.75	.79	ES350-4	84.3	NSTLESE6S	NSTLBSE6S
10"	2.68	20.35	22.01	9.51	4.54	10.63	7.99	9.72	(12) 7/8"-9	14.25	1.18	ES950-4	154.1	OSTLESE6S	OSTLBSE6S
12"	3.07	20.35	23.58	9.51	4.54	12.20	9.53	11.63	(12) 7/8"-9	17.00	1.18	ES950-4	228.1	PSTLESE6S	PSTLBSE6S

STL VALVE FEATURES

- Silicone free lug style butterfly valve.
- Ductile iron body.
- 316 stainless steel disc and 410 stainless steel stem.
- EPDM and BUNA-N seats.
- Mounting pad for direct mount actuator per ISO 5211.
- Pressure range: 29 inHg vacuum to 225 PSI.

PNEUMATIC ACTUATOR FEATURES

- E Series spring return rack and pinion actuator.
- Corrosion resistant coating.
- NAMUR solenoid mounting pad, ISO 5211 mounting standard.
- Visual position indicators.
- High duty cycle, permanent lubrication.
- Temperature range: -4°F to 175°F.

STLEDA Series 2" to 12" Sizes

Lug style butterfly valve with double acting pneumatic actuator

(Actuators are sized for 150 PSI liquid media line pressure, contact factory for higher line pressure ratings)

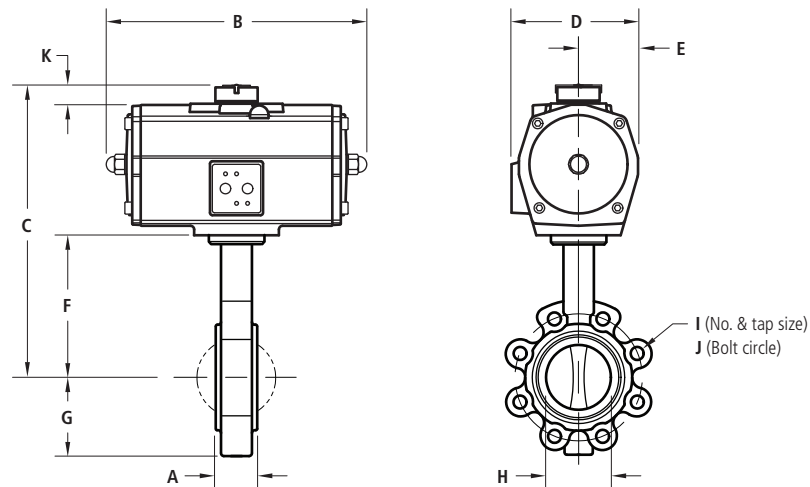

DIMENSIONS, WEIGHTS & SPECIFICATIONS

Size	A	B	C	D	E	F	G	H	I	J	K	Actuator	Wt. (lbs.)	Model No.	
														EPDM	BUNA-N
80 psig Minimum Actuator Air Supply = 8D															
2"	1.69	7.09	9.57	3.78	1.70	5.24	2.95	1.99	(4) 5/8"-11	4.75	.79	ED40	14.0	HSTLESE8D	HSTLBSE8D
2-1/2"	1.81	7.09	9.84	3.78	1.70	5.55	3.15	2.61	(4) 5/8"-11	5.50	.79	ED40	16.0	ISTLESE8D	ISTLBSE8D
3"	1.81	7.09	10.59	3.78	1.70	5.71	3.74	3.11	(4) 5/8"-11	6.00	.79	ED40	18.0	JSTLESE8D	JSTLBSE8D
4"	2.05	7.09	11.14	3.78	1.70	6.56	4.33	3.92	(8) 5/8"-11	7.50	.79	ED40	27.0	KSTLESE8D	KSTLBSE8D
5"	2.20	7.83	12.20	4.19	1.93	7.50	4.84	4.89	(8) 3/4"-10	8.50	.79	ED65	32.3	LSTLESE8D	LSTLBSE8D
6"	2.20	8.70	13.43	4.60	2.12	8.13	5.63	5.89	(8) 3/4"-10	9.50	.79	ED100	42.8	MSTLESE8D	MSTLBSE8D
8"	2.36	11.14	15.79	5.39	2.52	9.45	6.61	7.70	(8) 3/4"-10	11.75	.79	ED200	59.8	NSTLESE8D	NSTLBSE8D
10"	2.68	12.01	18.55	7.12	3.41	11.26	7.99	9.72	(12) 7/8"-9	14.25	.79	ED350	91.9	OSTLESE8D	OSTLBSE8D
12"	3.07	12.01	20.12	7.12	3.41	12.32	9.53	11.63	(12) 7/8"-9	17.00	.79	ED350	165.9	PSTLESE8D	PSTLBSE8D
60 psig Minimum Actuator Air Supply = 6D															
2"	1.69	7.09	9.57	3.78	1.70	5.24	2.95	1.99	(4) 5/8"-11	4.75	.79	ED40	14.0	HSTLESE6D	HSTLBSE6D
2-1/2"	1.81	7.09	9.84	3.78	1.70	5.55	3.15	2.61	(4) 5/8"-11	5.50	.79	ED40	16.0	ISTLESE6D	ISTLBSE6D
3"	1.81	7.09	10.59	3.78	1.70	5.71	3.74	3.11	(4) 5/8"-11	6.00	.79	ED40	18.0	JSTLESE6D	JSTLBSE6D
4"	2.05	7.09	11.14	3.78	1.70	6.56	4.33	3.92	(8) 5/8"-11	7.50	.79	ED40	27.0	KSTLESE6D	KSTLBSE6D
5"	2.20	8.70	12.27	4.60	2.12	7.50	4.84	4.89	(8) 3/4"-10	8.50	.79	ED100	33.8	LSTLESE6D	LSTLBSE6D
6"	2.20	11.14	14.41	5.39	2.52	8.13	5.63	5.89	(8) 3/4"-10	9.50	.79	ED200	48.8	MSTLESE6D	MSTLBSE6D
8"	2.36	11.14	15.79	5.39	2.52	9.45	6.61	7.70	(8) 3/4"-10	11.75	.79	ED200	59.8	NSTLESE6D	NSTLBSE6D
10"	2.68	12.01	18.55	7.12	3.41	11.26	7.99	9.72	(12) 7/8"-9	14.25	.79	ED350	91.9	OSTLESE6D	OSTLBSE6D
12"	3.07	15.24	22.04	8.52	4.08	12.32	9.53	11.63	(12) 7/8"-9	17.00	1.18	ED600	185.8	PSTLESE6D	PSTLBSE6D

STL VALVE FEATURES

- Silicone free lug style butterfly valve.
- Ductile iron body.
- 316 stainless steel disc and 410 stainless steel stem.
- EPDM and BUNA-N seats.
- Mounting pad for direct mount actuator per ISO 5211.
- Pressure range: 29 inHg vacuum to 225 PSI.

PNEUMATIC ACTUATOR FEATURES

- E Series double acting rack and pinion actuator.
- Corrosion resistant coating.
- NAMUR solenoid mounting pad, ISO 5211 mounting standard.
- Visual position indicators.
- High duty cycle, permanent lubrication.
- Temperature range: -4°F to 175°F.

STLB7 Series 2" to 6" Sizes

Lug style butterfly valve with explosion proof electric actuator, NEMA 7, 120 VAC
(Actuators are sized for 150 PSI liquid media line pressure, contact factory for higher line pressure ratings)

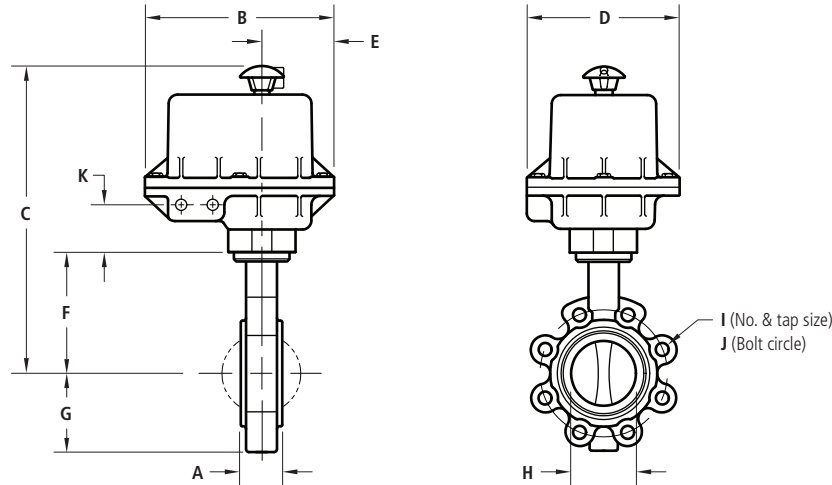

DIMENSIONS, WEIGHTS & SPECIFICATIONS

Size	A	B	C	D	E	F	G	H	I	J	K	Actuator	Wt. (lbs.)	Model No.	
														EPDM	BUNA-N
2"	1.69	9.75	14.56	7.75	3.75	5.12	2.95	1.99	(4) 5/8"-11	4.75	2.44	BEEM500F	28.0	HSTLESB7	HSTLBSB7
2-1/2"	1.81	9.75	14.83	7.75	3.75	5.39	3.15	2.61	(4) 5/8"-11	5.50	2.44	BEEM500F	30.0	ISTLESB7	ISTLBSB7
3"	1.81	9.75	15.58	7.75	3.75	6.14	3.74	3.11	(4) 5/8"-11	6.00	2.44	BEEM500F	32.0	JSTLESB7	JSTLBSB7
4"	2.05	9.75	16.13	7.75	3.75	6.69	4.33	3.92	(8) 5/8"-11	7.50	2.44	BEEM500F	41.0	KSTLESB7	KSTLBSB7
5"	2.20	9.75	16.72	7.75	3.75	7.28	4.84	4.89	(8) 3/4"-10	8.50	2.44	BEEM500F	45.0	LSTLESB7	LSTLBSB7
6"	2.20	9.75	17.43	7.75	3.75	7.99	5.63	5.89	(8) 3/4"-10	9.50	2.44	BEEM500F	54.0	MSTLESB7	MSTLBSB7

STL VALVE FEATURES

- Silicone free lug style butterfly valve.
- Ductile iron body.
- 316 stainless steel disc and 410 stainless steel stem.
- EPDM and BUNA-N seats.
- Mounting pad for direct mount actuator per ISO 5211.
- Pressure range: 29 inHg vacuum to 225 PSI.

ELECTRIC ACTUATOR FEATURES

- B7 Series electric actuator.
- Actuator speed: 15 sec.
- NEMA 4, 4x, 7 and 9; CSA approved.
- Weatherproof.
- Class I Groups C and D, Div. 1.
- Class II Groups E, F and G.
- (2) 1/2" NPT conduit entries.
- Manual override.
- Position indicator.
- CSA certified.
- Temperature range: 0°F to 160°F.

STLB7 Series 8" to 12" Sizes

Lug style butterfly valve with explosion proof electric actuator, NEMA 7, 120 VAC
(Actuators are sized for 150 PSI liquid media line pressure, contact factory for higher line pressure ratings)

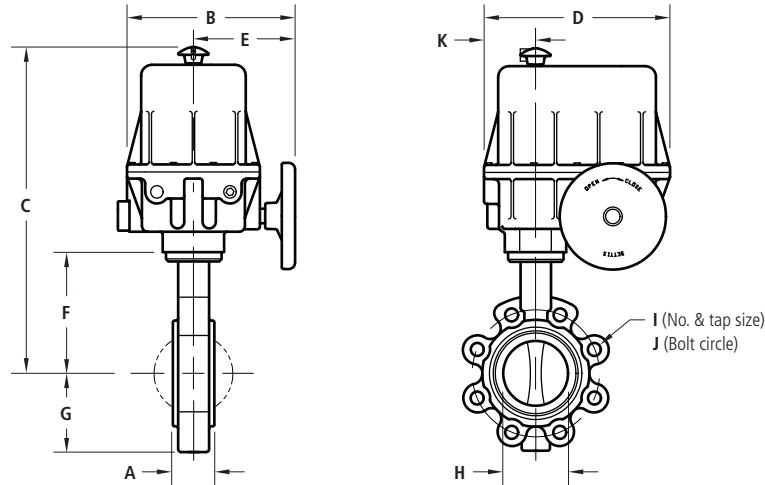

DIMENSIONS, WEIGHTS & SPECIFICATIONS

Size	A	B	C	D	E	F	G	H	I	J	K	Actuator	Wt. (lbs.)	Model No.	
														EPDM	BUNA-N
8"	2.36	13.31	18.81	14.00	7.62	9.37	6.61	7.70	(8) 3/4"-10	11.75	3.88	BEEM82018C	207	NSTLESB7	NSTLBSB7
10"	2.68	13.31	20.07	14.00	7.62	10.63	7.99	9.72	(12) 7/8"-9	14.50	3.88	BEEM82018C	229	OSTLESB7	OSTLBSB7
12"	3.07	13.31	21.64	14.00	7.62	12.20	9.53	11.63	(12) 7/8"-9	17.00	3.88	BEEM82018C	303	PSTLESB7	PSTLBSB7

STL VALVE FEATURES

- Silicone free lug style butterfly valve.
- Ductile iron body.
- 316 stainless steel disc and 410 stainless steel stem.
- EPDM and BUNA-N seats.
- Mounting pad for direct mount actuator per ISO 5211.
- Pressure range: 29 inHg vacuum to 225 PSI.

ELECTRIC ACTUATOR FEATURES

- B7 Series electric actuator.
- Actuator speed: 18 sec.
- NEMA 4, 7 and 9; CSA approved.
- Weatherproof.
- Class I Groups C and D, Div. 1.
- Class II Groups E, F and G.
- (2) 1/2" NPT conduit entries.
- Manual override.
- Position indicator.
- CSA certified.
- Temperature range: 0°F to 160°F.

STLK4 Series 14" to 24" Sizes

Lug style butterfly valve with electric actuator

(Actuators are sized for 50 PSI liquid media line pressure, contact factory for higher line pressure ratings)

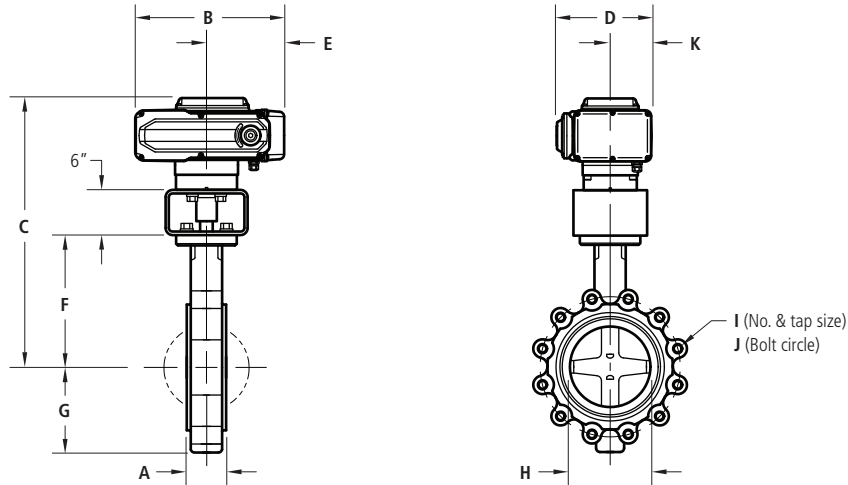

DIMENSIONS, WEIGHTS & SPECIFICATIONS

Size	A	B	C	D	E	F	G	H	I	J	K	Actuator	Wt. (lbs.)	Model No.	
														EPDM	BUNA-N
14"	3.07	15.00	28.81	9.53	4.08	13.60	10.41	12.99	(12) 1"-8	18.75	4.13	UNIC100	216	QSTLESK4	QSTLBSK4
16"	4.02	15.00	28.97	9.53	4.54	13.76	11.75	14.92	(16) 1"-8	21.25	4.13	UNIC100	316	RSTLESK4	RSTLBSK4
18"	4.49	15.00	30.96	9.53	4.54	15.75	13.78	17.20	(16) 1.12"-7	22.75	4.13	UNIC100	383	SSTLESK4	SSTLBSK4
20"	5.00	15.00	32.53	9.53	5.21	17.32	14.96	19.29	(20) 1.12"-7	25.00	4.13	UNIC100	585	TSTLESK4	TSTLBSK4
24"	Consult Factory														

STL VALVE FEATURES

- Silicone free lug style butterfly valve.
- Ductile iron body.
- 316 stainless steel disc and 410 stainless steel stem.
- EPDM and BUNA-N seats.
- Mounting pad for direct mount actuator per ISO 5211.
- Pressure range: 29 inHg vacuum to 160 PSI.

ELECTRIC ACTUATOR FEATURES

- K Series electric actuator.
- Actuator speed: 25 sec.
- Most voltages available.
- Quarter turn: 0-90° rotation.
- NEMA 4/4X certified by UL labs.
- ISO 5211 mounting standard.
- Visual position indicators.
- Self-locking drive train.
- Mounts in any direction.
- 1/2" NPT conduit connection.
- CSA-NRTL/C and CE certified.
- Temperature range: 0°F to 160°F.

STLESR Series 14" to 24" Sizes

Lug style butterfly valve with spring return pneumatic actuator

(Actuators are sized for 50 PSI liquid media line pressure, contact factory for higher line pressure ratings)

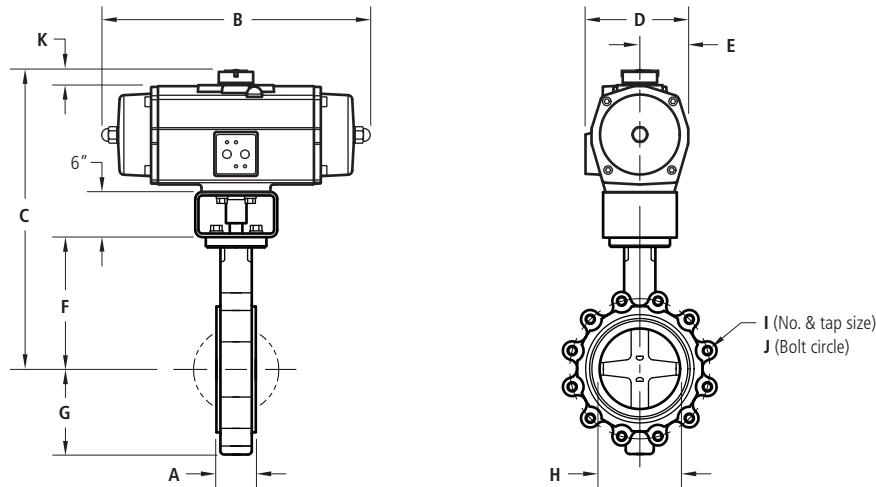

DIMENSIONS, WEIGHTS & SPECIFICATIONS

Size	A	B	C	D	E	F	G	H	I	J	K	Actuator	Wt. (lbs.)	Model No.	
														EPDM	BUNA-N
80 psig Minimum Actuator Air Supply = 85															
14"	3.07	18.75	29.44	8.52	4.08	13.60	10.41	12.99	(12) 1"-8	18.75	1.18	ES600-4	229	QSTLESE8S	QSTLBSE8S
16"	4.02	20.35	31.14	9.51	4.54	13.76	11.75	14.92	(16) 1"-8	21.25	1.18	ES950-4	353	RSTLESE8S	RSTLBSE8S
18"	4.49	20.35	33.13	9.51	4.54	15.75	13.78	17.20	(16) 1.12"-7	22.75	1.18	ES950-4	420	SSTLESE8S	SSTLBSE8S
20"	5.00	15.24	36.19	10.81	5.21	17.32	14.96	19.29	(20) 1.12"-7	25.00	1.18	ES1600-4	682	TSTLESE8S	TSTLBSE8S
24"	6.06	22.44	41.28	14.17	6.89	20.08	17.32	22.62	(20) 1.25"-7	29.50	1.18	PS2505-14	905	USTLESE8S	USTLBSE8S
60 psig Minimum Actuator Air Supply = 65															
14"	3.07	20.35	30.98	9.51	4.54	13.60	10.41	12.99	(12) 1"-8	18.75	1.18	ES950-3	253	QSTLESE6S	QSTLBSE6S
16"	4.02	20.35	31.14	9.51	4.54	13.76	11.75	14.92	(16) 1"-8	21.25	1.18	ES950-3	353	RSTLESE6S	RSTLBSE6S
18"	4.49	25.08	34.62	10.81	5.21	15.75	13.78	17.20	(16) 1.12"-7	22.75	1.18	ES1600-3	480	SSTLESE6S	SSTLBSE6S
20"	5.00	25.08	36.19	10.81	5.21	17.32	14.96	19.29	(20) 1.12"-7	25.00	1.18	ES1600-3	682	TSTLESE6S	TSTLBSE6S
24"	6.06	32.83	42.22	15.35	7.48	20.08	17.32	22.62	(20) 1.25"-7	29.50	1.18	PS4005-8	1002	USTLESE6S	USTLBSE6S

STL VALVE FEATURES

- Silicone free lug style butterfly valve.
- Ductile iron body.
- 316 stainless steel disc and 410 stainless steel stem.
- EPDM and BUNA-N seats.
- Mounting pad for direct mount actuator per ISO 5211.
- Pressure range: 29 inHg vacuum to 160 PSI.

PNEUMATIC ACTUATOR FEATURES

- E Series spring return rack and pinion actuator.
- Corrosion resistant coating.
- NAMUR solenoid mounting pad, ISO 5211 mounting standard.
- Visual position indicators.
- High duty cycle.
- Permanent lubrication.
- Temperature range: -4°F to 175°F.

STLEDA Series 14" to 24" Sizes

Lug style butterfly valve with double acting pneumatic actuator

(Actuators are sized for 50 PSI liquid media line pressure, contact factory for higher line pressure ratings)

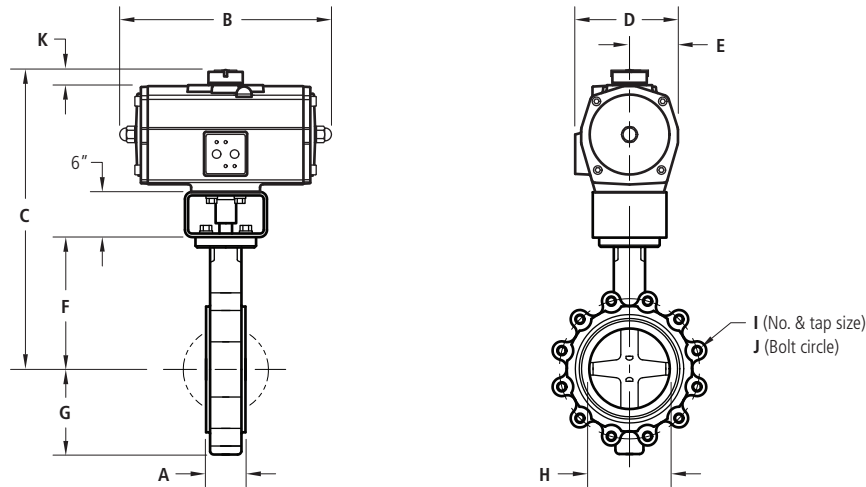

DIMENSIONS, WEIGHTS & SPECIFICATIONS

Size	A	B	C	D	E	F	G	H	I	J	K	Actuator	Wt. (lbs.)	Model No.	
														EPDM	BUNA-N
80 psig Minimum Actuator Air Supply = 8D															
14"	3.07	12.01	27.52	7.12	6.41	13.60	10.41	12.99	(12) 1"-8	18.75	.79	ED350	191	QSTLESE8D	QSTLBSE8D
16"	4.02	15.24	29.60	8.52	4.08	13.76	11.75	14.92	(16) 1"-8	21.25	1.18	ED600	311	RSTLESE8D	RSTLBSE8D
18"	4.49	15.24	31.59	8.52	4.08	15.75	13.78	17.20	(16) 1.12"-7	22.75	1.18	ED600	378	SSTLESE8D	SSTLBSE8D
20"	5.00	15.24	33.16	8.52	4.08	17.32	14.96	19.29	(20) 1.12"-7	25.00	1.18	ED600	580	TSTLESE8D	TSTLBSE8D
24"	6.06	20.31	38.95	10.81	5.21	20.08	17.32	22.62	(20) 1.25"-7	29.50	1.18	ED1600	805	USTLESE8D	USTLBSE8D
60 psig Minimum Actuator Air Supply = 6D															
14"	3.07	12.01	27.52	7.12	6.41	13.60	10.41	12.99	(12) 1"-8	18.75	.79	ED350	191	QSTLESE6D	QSTLBSE6D
16"	4.02	15.24	29.60	8.52	4.08	13.76	11.75	14.92	(16) 1"-8	21.25	1.18	ED600	311	RSTLESE6D	RSTLBSE6D
18"	4.49	15.24	31.59	8.52	4.08	15.75	13.78	17.20	(16) 1.12"-7	22.75	1.18	ED600	378	SSTLESE6D	SSTLBSE6D
20"	5.00	16.69	34.70	9.51	4.54	17.32	14.96	19.29	(20) 1.12"-7	25.00	1.18	ED950	595	TSTLESE6D	TSTLBSE6D
24"	6.06	20.31	38.95	10.81	5.21	20.08	17.32	22.62	(20) 1.25"-7	29.50	1.18	ED1600	805	USTLESE6D	USTLBSE6D

STL VALVE FEATURES

- Silicone free lug style butterfly valve.
- Ductile iron body.
- 316 stainless steel disc and 410 stainless steel stem.
- EPDM and BUNA-N seats.
- Mounting pad for direct mount actuator per ISO 5211.
- Pressure range: 29 inHg vacuum to 160 PSI.

PNEUMATIC ACTUATOR FEATURES

- E Series double acting rack and pinion actuator.
- Corrosion resistant coating.
- NAMUR solenoid mounting pad, ISO 5211 mounting standard.
- Visual position indicators.
- High duty cycle.
- Permanent lubrication.
- Temperature range: -4°F to 175°F.

STLB7 Series 14" to 24" Sizes

Lug style butterfly valve with explosion proof electric actuator, NEMA 7, 120 VAC
(Actuators are sized for 50 PSI liquid media line pressure, contact factory for higher line pressure ratings)

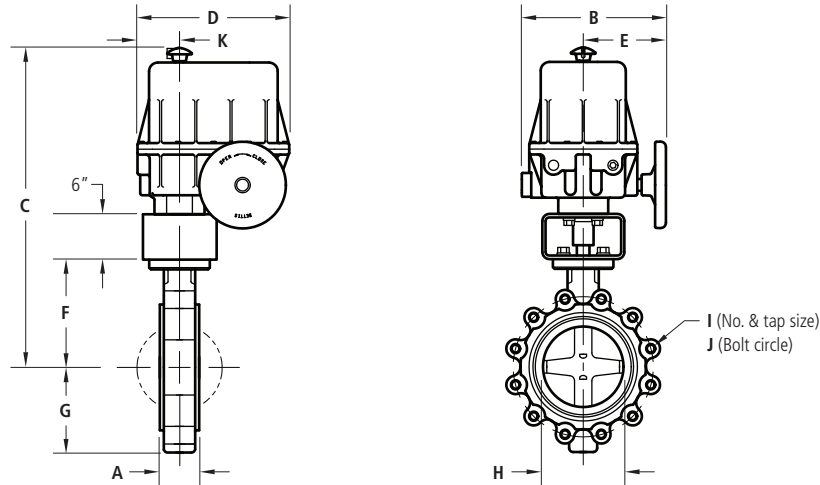

DIMENSIONS, WEIGHTS & SPECIFICATIONS

Size	A	B	C	D	E	F	G	H	I	J	K	Actuator	Wt. (lbs.)	Model No.	
														EPDM	BUNA-N
14"	3.07	13.31	34.98	14.00	7.62	13.60	10.41	12.99	(12) 1"-8	18.75	3.88	BEEM82018C	328	QSTLESB7	QSTLBSB7
16"	4.02	13.31	35.14	14.00	7.62	13.76	11.75	14.92	(16) 1"-8	21.25	3.88	BEEM82018C	428	RSTLESB7	RSTLBSB7
18"	4.49	13.31	37.13	14.00	7.62	15.75	13.78	17.20	(16) 1.12"-7	22.75	3.88	BEEM83030C	495	SSTLESB7	SSTLBSB7
20"	5.00	13.31	38.70	14.00	7.62	17.32	14.96	19.29	(20) 1.12"-7	25.00	3.88	BEEM83030C	697	TSTLESB7	TSTLBSB7
24"	6.06	13.31	41.46	14.00	7.62	20.08	17.32	22.62	(20) 1.25"-7	29.50	3.88	BEEM83030C	871	USTLESB7	USTLBSB7

STL VALVE FEATURES

- Silicone free lug style butterfly valve.
- Ductile iron body.
- 316 stainless steel disc and 410 stainless steel stem.
- EPDM and BUNA-N seats.
- Mounting pad for direct mount actuator per ISO 5211.
- Pressure range: 29 inHg vacuum to 160 PSI.

ELECTRIC ACTUATOR FEATURES

- B7 Series electric actuator.
- Actuator speed: 18 sec. (14" to 16"), 30 sec. (18" to 24").
- NEMA 4, 7 and 9; CSA approved.
- Weatherproof.
- Class I Groups C and D, Div. 1.
- Class II Groups E, F and G.
- (2) 1/2" NPT conduit entries.
- Manual override.
- Position indicator.
- CSA certified.
- Temperature range: 0°F to 160°F.

STLI4 Series

Lug style butterfly valve with electric actuator

(Actuators are sized for 150 PSI liquid media line pressure, contact factory for higher line pressure ratings)

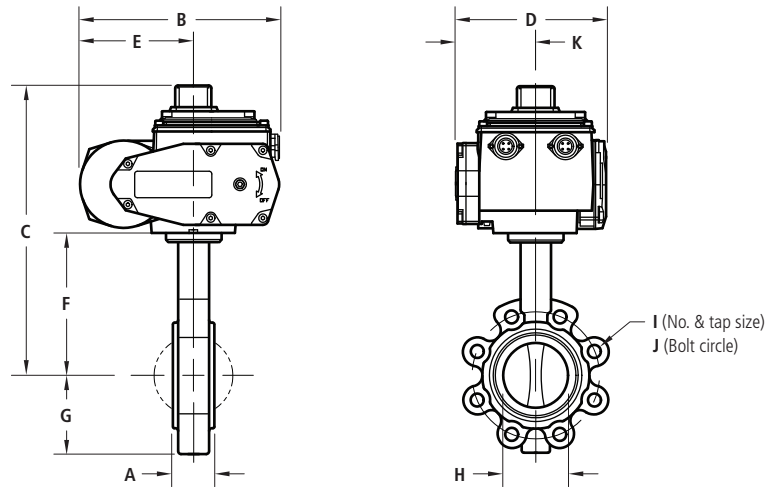

DIMENSIONS, WEIGHTS & SPECIFICATIONS

Size	A	B	C	D	E	F	G	H	I	J	K	Actuator	Wt. (lbs.)	Model No.	
														EPDM	BUNA-N
2"	1.69	7.56	10.64	5.36	3.58	5.12	2.95	1.99	(4) 5/8"-11	4.75	2.37	I4600	17.9	HSTLES14	HSTLBS14
2-1/2"	1.81	7.56	10.95	5.36	3.58	5.39	3.15	2.61	(4) 5/8"-11	5.50	2.37	I4600	19.9	ISTLES14	ISTLBS14
3"	1.81	7.56	11.11	5.36	3.58	6.14	3.74	3.11	(4) 5/8"-11	6.00	2.37	I4600	21.9	JSTLES14	JSTLBS14
4"	2.05	7.56	11.96	5.36	3.58	6.69	4.33	3.92	(8) 5/8"-11	7.50	2.37	I4600	30.9	KSTLES14	KSTLBS14
5"	2.20	7.56	12.90	5.36	3.58	7.28	4.84	4.89	(8) 3/4"-10	8.50	2.37	I4600	34.9	LSTLES14	LSTLBS14
6"	2.20	8.73	14.30	6.30	4.75	7.99	5.63	5.89	(8) 3/4"-10	9.50	3.31	I41150	52.5	MSTLES14	MSTLBS14
8"	2.36	8.73	15.62	6.30	4.75	9.37	6.61	7.70	(8) 3/4"-10	11.75	3.31	I41150	63.5	NSTLES14	NSTLBS14
10"	2.68	8.73	17.43	6.30	4.75	10.63	7.99	9.72	(12) 7/8"-9	14.25	3.31	I42100	85.5	OSTLES14	OSTLBS14
12"	3.07	8.73	18.49	6.30	4.75	12.20	9.53	11.63	(12) 7/8"-9	17.00	3.31	I42100	159.5	PSTLES14	PSTLBS14

STL VALVE FEATURES

- Silicone free lug style butterfly valve.
- Ductile iron body.
- 316 stainless steel disc and 410 stainless steel stem.
- EPDM and BUNA-N seats.
- Mounting pad for direct mount actuator per ISO 5211.
- Pressure range: 29 inHg vacuum to 160 PSI.

ELECTRIC ACTUATOR FEATURES

- I4 Series electric actuator.
- Weatherproof enclosure IP65.
- Voltages available: 115 VAC, 24 VAC/VDC.
- Duty cycle: 50%.
- IP65 electrical connectors.
- Space heater.
- Extra (2) SPDT adjustable limit switches.
- Temperature range: 0°F to 140°F.