

# FM FIRE-SAFE VALVE ASSEMBLIES & ACTUATORS



## Fire-Safe Valve and Actuator Assembly

*Operator's Manual*

OPERATOR'S MANUAL

# FM FIRE-SAFE VALVE AND ACTUATOR ASSEMBLY

Assured Automation | 19 Walnut Avenue | Clark, NJ 07066  
P 1-800-899-0553 | F 732-381-2328 | assuredautomation.com

**Customer Service / Technical Service: 1-800-899-0553**

FM Fire-Safe valve assemblies and actuators in this catalogue are manufactured by Essex™ Industries.

# TABLE OF CONTENTS

<b>1. TYPES OF ACTUATORS .....</b>	<b>5</b>
1.1. THERMAL LINK ACTUATORS.....	5
1.2. ELECTRO-THERMAL LINK (ETL) ACTUATORS.....	5
<b>2. THERMAL ACTUATOR / BALL VALVE INSTALLATION INSTRUCTIONS .....</b>	<b>6</b>
2.1. THREADED BALL VALVE INSTALLATIONS.....	6
2.2. WELDED BALL VALVE INSTALLATIONS .....	7
<b>3. ELECTRO-THERMAL ACTUATOR / BALL VALVE INSTALLATION INSTRUCTIONS ....</b>	<b>9</b>
3.1. ELECTRO-THERMAL LINK ACTUATOR ASSEMBLY ELECTRICAL HOOK-UP INSTRUCTIONS .....	9
<b>4. THERMAL ACTUATOR / BUTTERFLY VALVE INSTALLATION INSTRUCTIONS .....</b>	<b>10</b>
<b>5. ELECTRO-THERMAL ACTUATOR / BUTTERFLY VALVE INSTALLATION INSTRUCTIONS FEATURES .....</b>	<b>12</b>
5.1. ELECTRO-THERMAL LINK ACTUATOR ASSEMBLY ELECTRICAL HOOK-UP INSTRUCTIONS .....	12
<b>6. ACTUATOR REPLACEMENT INSTRUCTIONS.....</b>	<b>13</b>
6.1. TO REMOVE THE ENTIRE ACTUATOR / BALL VALVE ASSEMBLY .....	13
6.2. TO REMOVE A FIRED ACTUATOR FROM BALL OR BUTTERFLY VALVE .....	13
6.3. TO REMOVE AN UN-FIRED ACTUATOR FROM BALL OR BUTTERFLY VALVE.....	13
6.4. TO REPLACE A LOADED ACTUATOR ONTO A BALL VALVE.....	14
6.5. TO REPLACE A LOADED ACTUATOR ONTO A BUTTERFLY VALVE.....	15
<b>7. LIMITED WARRANTY .....</b>	<b>16</b>

# LIST OF FIGURES AND TABLES

Figure 1 - Thermal Link Actuator ..... 5

Figure 2 - Electro-Thermal Link Actuator ..... 5

Figure 3 - How to Use Removable Handle ..... 7

Figure 4 - How to Use Removable Handle ..... 8

Figure 5 - How to Use Removable Handle to Set Valve Position ..... 10

Figure 6 - Mounting Actuator to Bracket on Butterfly Valve ..... 11

Figure 7 - Applying Molykote..... 14

Figure 8 - Assembled Actuator on Valve ..... 15

# 1. TYPES OF ACTUATORS

## 1.1. Thermal Link Actuators

1. Thermal Link Actuators are designed to react (melt) when subjected to local heat (165° F or alternate temperature as ordered) activating (closing or opening) the Valve the Actuator is mounted to.

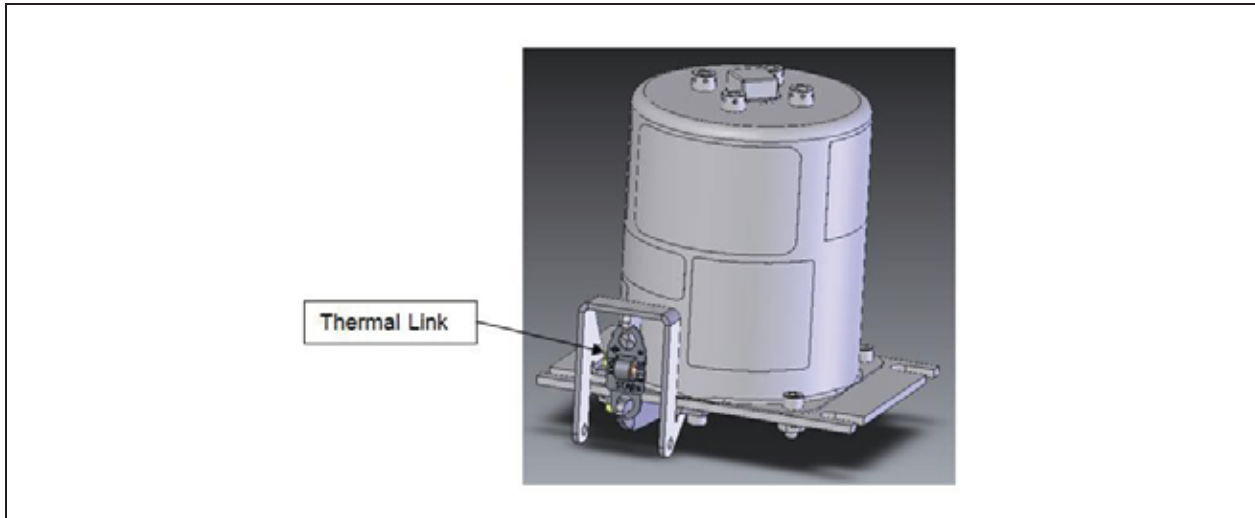

Figure 1 - Thermal Link Actuator

## 1.2. Electro-Thermal Link (ETL) Actuators

1. Electro-Thermal Link Actuators are designed to:
  - React (melt) when subjected to local heat (165° F or alternate temperature as ordered) activating (closing or opening) the Valve the Actuator is mounted to.
  - React (melt) when subjected to an external electrical impulse of low power over an extremely short period of time activating (closing or opening) the Valve the Actuator is mounted to.

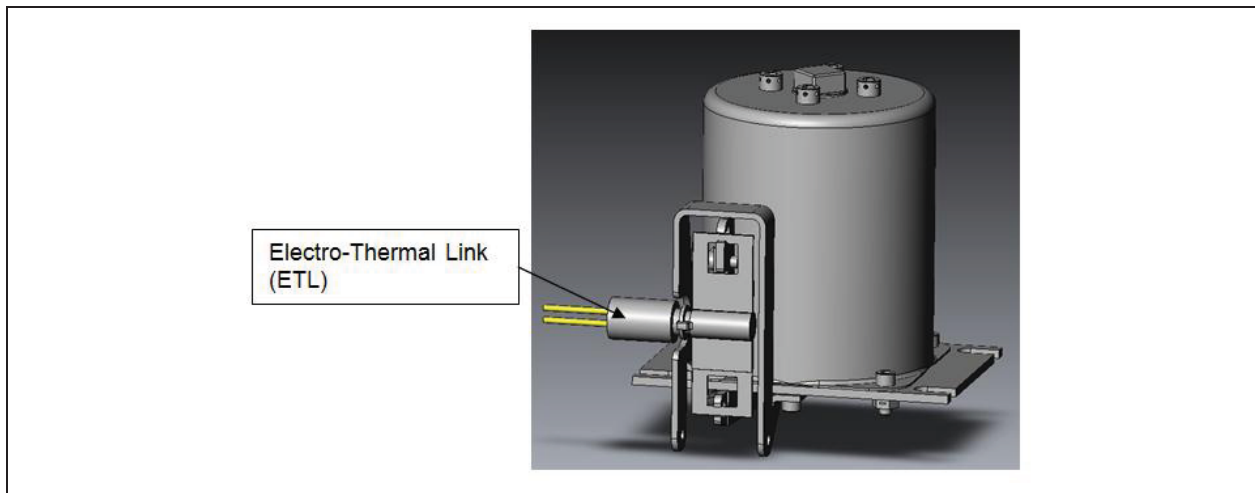

Figure 2 - Electro-Thermal Link Actuator

## 2. THERMAL ACTUATOR / BALL VALVE INSTALLATION INSTRUCTIONS

### 2.1. Threaded Ball Valve Installations

1. Installation of threaded Ball Valve and Actuator Assembly is straight- forward, and simple, however a few considerations or checks can prevent possible future problems.
  - Do not remove the fasteners that hold the Bracket to the Valve Body.
  - Do not remove the fasteners that hold the Actuator to the Bracket.
  - Although the Ball Valve has great structural integrity, severe misalignment and/or pulling apart of the adjoining pipe has detrimental effect on the Valve and should be avoided.
  - Standard OEM Ball Valve installation procedures should be followed.
  - Over-tightening as with all pipe fittings can result in stripped threads and/or misalignment, or cause defective end caps.
  - Do not use the Actuator or Bracketry for leverage when installing and operating.
  - If there are any dents or obvious signs of damage to Actuator Canister or Actuator, return to vendor for exchange.
  - The flanged end Valves can be used with all standard sized nuts, however, heavy duty nuts are usable on all standard ported 150-pound flanged end Valves.
  - Store the assembly in an area below 120° F (49° C) prior to installation.
2. After installation, open and close Valve several times using removable Handle (see Figure 3), to be sure that it operates smoothly. Handle is to engage with flats on Stem Coupling as shown in Figure 3.

**Note: Like any quarter-turn Valve, the Thermal Shut-off Valve should be operated by the removable Handle periodically to prevent sticking due to corrosion, freezing, etc., to assure smooth operation or firing during the life of the Valve.**

#### **WARNINGS/CAUTIONS**

- **At no time should the removable Handle be left in Valve after manually operating (to and open or closed position).**
- **Valve is quick-acting with closing/opening speeds recorded of less than one (1) millisecond.**

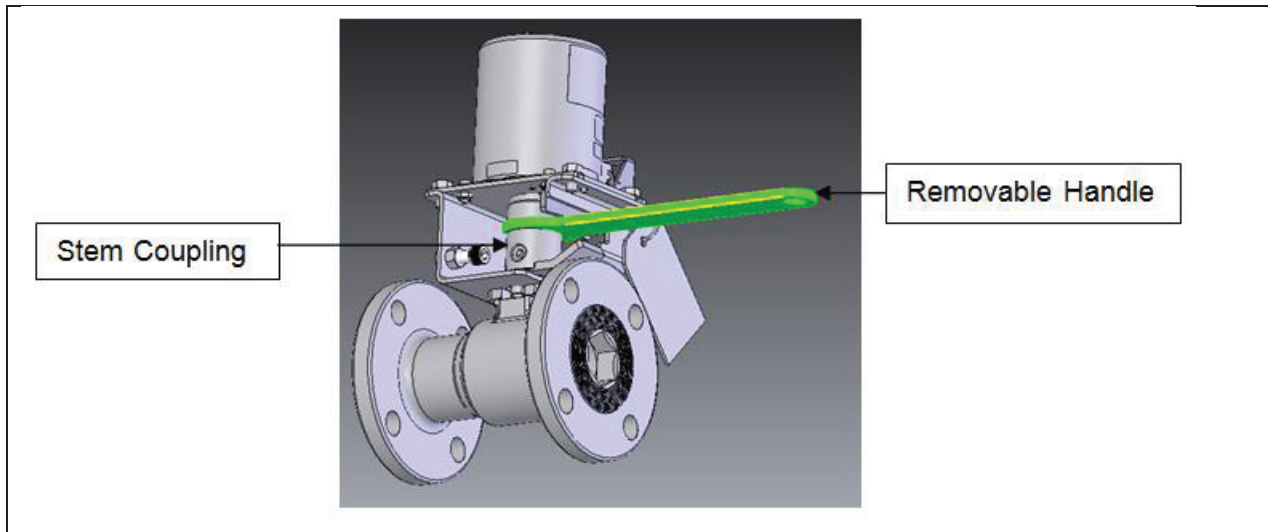

Figure 3 - How to Use Removable Handle

3. Remove the Safety Pin as noted on the Warning Ribbon when the Valve is put into operation. The Actuator will not operate with the Safety Pin in place.

### **WARNINGS/CAUTIONS**

- **Replace the Safety Pin if for any reason the Valve is removed from service before the valve has been fired by the Actuator.**
- **After the Valve has been operated by the Actuator, the Actuator assembly must be returned to Essex Industries for rework and replacement of critical parts (see 6.2).**
- **Do not attempt to remove the Actuator Cover of the Actuator. The Spring(s) retain tension to maintain the Valve in the open or closed position after it has been fired (actuated).**
- **Never put hands or fingers in area of Valve closing member without the Safety Pin in place.**

## **2.2. WELDED BALL VALVE INSTALLATIONS**

1. Seats in this Valve will be damaged if welding is not done in accordance with Original Equipment Manufacturer's (OEM's) procedures.

### **WARNINGS/CAUTIONS**

- **Do not remove the fasteners that hold the Bracket to the Valve Body.**
- **Do not remove the fasteners that hold the Actuator to the Bracket.**
- **Do not remove the Safety Pin during the weld-in procedure.**
- **Follow the weld-in procedure per the OEM's procedures.**

2. After welding, open and close Valve several times using removable Handle (see Figure 4), to be sure that it operates smoothly. Handle is to engage with flats on Stem Coupling as shown in Figure 4.

**Note:** Like any quarter-turn Valve, the Thermal Shut-off Valve should be operated by the removable Handle periodically to prevent sticking due to corrosion, freezing, etc., to assure smooth operation or firing during the life of the Valve.

### WARNINGS/CAUTIONS

- At no time should the removable Handle be left in Valve after manually operating (to and open or closed position).
- Valve is quick-acting with closing/opening speeds recorded of less than one (1) millisecond.

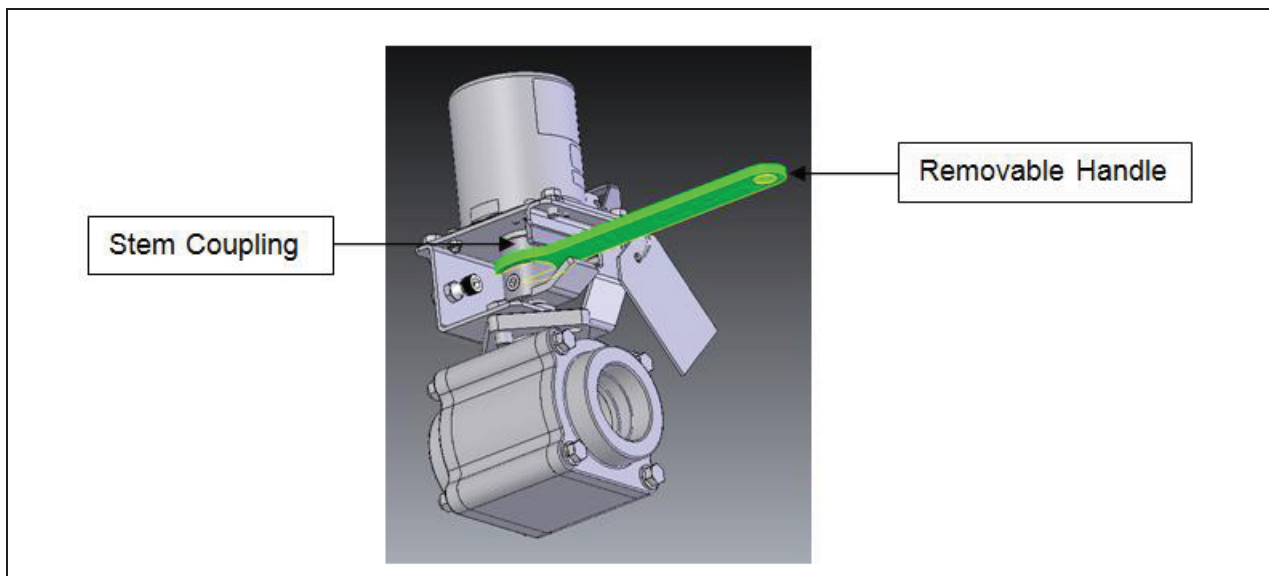

Figure 4 - How to Use Removable Handle

3. Remove the Safety Pin as noted on the Warning Ribbon when the valve is put into operation. The Actuator will not operate with the Safety Pin in place.

### WARNINGS/CAUTIONS

- Replace the Safety Pin if for any reason the Valve is removed from service before the Valve has been fired by the Actuator.
- After the Valve has been operated by the Actuator, the Actuator assembly must be returned to Essex Industries for rework and replacement of critical parts (see 6.2).
- Do not attempt to remove the Actuator Cover of the Actuator. The Spring(s) retain tension to maintain the Valve in the open or closed position after it has been fired (actuated).
- Never put hands or fingers in area of Valve closing member without the Safety Pin in place.



### 3. ELECTRO-THERMAL ACTUATOR / BALL VALVE INSTALLATION INSTRUCTIONS

#### 3.1. ELECTRO-THERMAL LINK ACTUATOR ASSEMBLY ELECTRICAL HOOK-UP INSTRUCTIONS

**Notes:**

- A) ETL Actuator / Valve Assembly should be installed as detailed in steps 2.1 & 2.2 of the Thermal Actuator / Ball Valve installation instructions above prior to completion of the electrical hook-up of the Electro-Thermal Actuator.
- B) The ETL is designed to react to an electrical impulse of 0.2 amps over a short period of time (less than 1 millisecond) at a voltage range of 6-30 volts AC or DC low voltage NEC Class 2. Power may be taken from a low voltage Class 2 source (found on most smoke detectors) and switched through any appropriately rated normally open set of contacts in the detector, so that the ETL will be impulsed upon detection of smoke. Similar circuitry may be used with rate of rise detectors or any normally open manual or automatic alarm switch.
1. The wiring is subject to the National Electrical Code Par. 300-22, which requires the use of metallic protection of all such wirings. Accordingly, the ETL has the same diameter on the wire end as 1/2" electrical metallic tubing (EMT) permitting standard, UL listed connectors, either 3/8" flex to 1/2" EMT, or 1/2" EMT to 1/2" EMT to be used, together with the appropriate flexible conduit, to completely encase the wires in metal.
  2. Prior to making the final wiring connection, energize the power source and check for proper voltage with a Voltmeter. At the same time an Ohmmeter with output not to exceed 10 milli-amperes should be connected to the leads of the ETL to test for continuity. If the resistance is not within 10 to 30 ohms, remove the Actuator and return it or exchange.

#### **WARNINGS/CAUTIONS**

- **Be sure the circuit is de-energized before connecting the ETL leads to the power source.**
- **Most detectors send out a low power battery signal. When battery voltage becomes weak, this signal may activate the Valve unless detector is of the type that allows for this condition without the sending a low power signal.**
- **Warranty is voided if ETL is used in monitored systems with more than an absolutely limited one (1) milli-ampere maximum input constant current.**

## 4. THERMAL ACTUATOR / BUTTERFLY VALVE INSTALLATION INSTRUCTIONS

### Notes:

- A) The Butterfly Valve and Actuator are shipped in two (2) parts to allow the Butterfly Valve with Bracketry to be set in the desired position before installation of the Actuator onto the Butterfly Valve.
- B) Due to the design of the Butterfly Actuators, the Valve cannot be operated manually while the Actuator is attached.
1. Installation of Butterfly Valve is straight- forward, and simple, however a few considerations or checks can prevent possible future problems.
    - 1.1. Although the Butterfly Valve has great structural integrity, severe misalignment and/or pulling apart of the adjoining pipe has detrimental effect on the Butterfly Valve and should be avoided.
    - 1.2. Standard OEM Butterfly Valve installation procedures should be followed.
  2. Verify the Safety Pin is installed in the Actuator prior to installation of the Actuator onto the Butterfly Valve.
  3. Remove 4 each Whiz Lock® screws and remove Shipping Plate from Bracket mounted on Butterfly Valve.
  4. Use the removable Handle to set the Valve in one of the four desired positions (0°, 30°, 60°, or 90°).

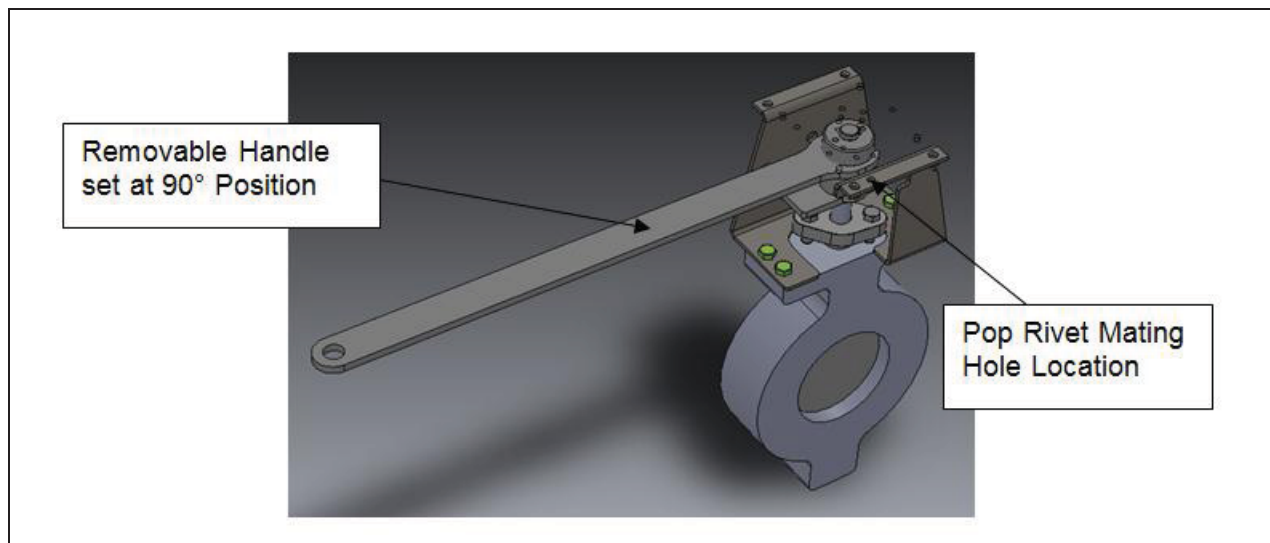
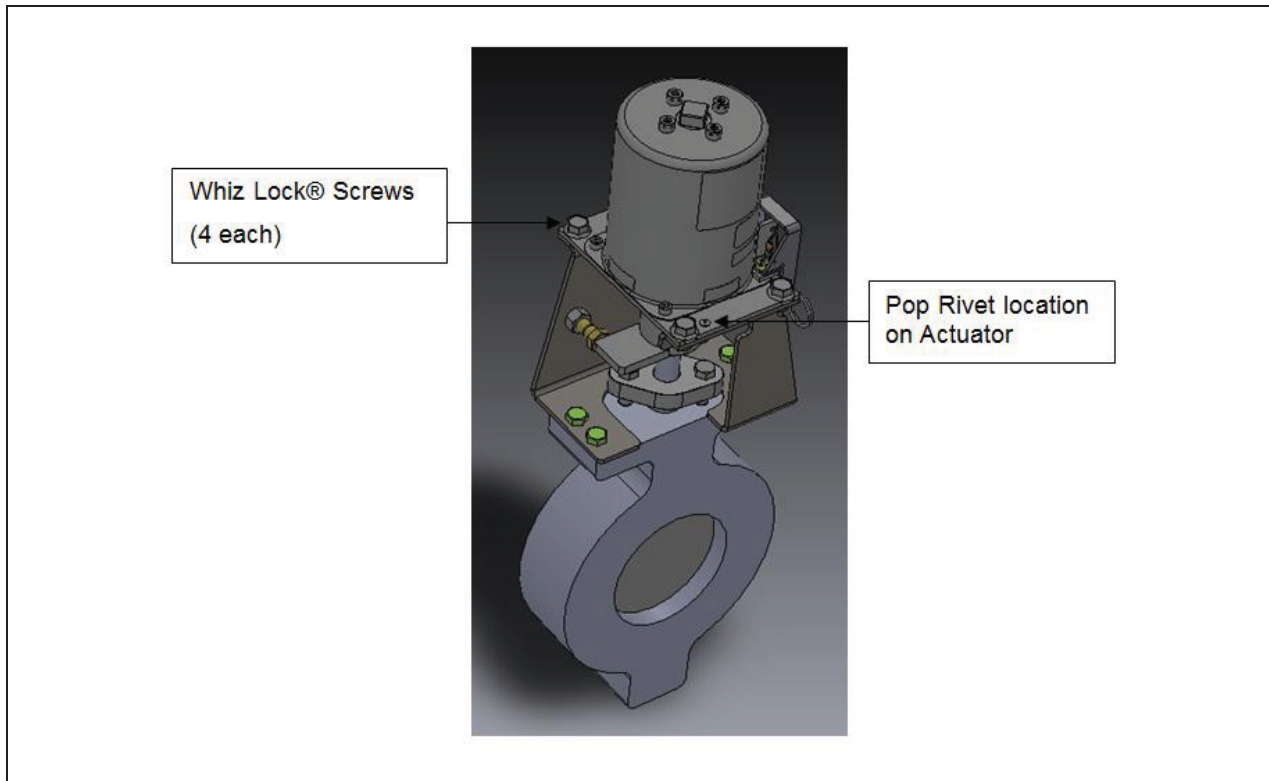

Figure 5 - How to Use Removable Handle to Set Valve Position

5. Place the Actuator on top of the Bracket so the Pop Rivet on the Actuator engages with the mating hole in the Bracket, while aligning the two Stem Coupling Pins to the bottom of the Actuator.

**Notes:**

- A) Locate the Pop Rivet on the Actuator and its mating hole in the Bracket. The Pop Rivet is designed to aid in correctly positioning the Actuator on the Bracket.
  - B) It may be necessary to slightly turn the Stem Coupler with the removable Handle to align the Actuator and Lower Coupling with the Stem Coupler and Bracket.
6. Secure the Actuator to the Bracket using four (4) Whiz Lock® screws, torqued at  $250 \pm 12$  in-lbs. The use of this fastener is critical and a substitute should not be used.



**Figure 6 - Mounting Actuator to Bracket on Butterfly Valve**

7. Remove the Safety Pin as noted on the Warning Ribbon when the Valve is put into operation. The Actuator will not operate with the Safety Pin in place.

### **WARNINGS/CAUTIONS**

- **Replace the Safety Pin if for any reason the Valve is removed from service before the Valve has been fired by the Actuator.**
- **After the Valve has been operated by the Actuator, the Actuator must be returned to Essex Industries for rework and replacement of critical parts (see 6.2).**
- **Do not attempt to remove the Actuator Cover of the Actuator. The Spring(s) retain tension to maintain the Valve in the open or closed position after it has been fired (actuated).**
- **Never put hands or fingers in area of Valve closing member without the Safety Pin in place.**

## 5. ELECTRO-THERMAL ACTUATOR / BUTTERFLY VALVE INSTALLATION INSTRUCTIONS FEATURES

### 5.1. ELECTRO-THERMAL LINK ACTUATOR ASSEMBLY ELECTRICAL HOOK-UP INSTRUCTIONS

**Notes:**

- A) ETL Actuator / Valve Assembly should be installed as detailed in 4. Thermal Actuator / Butterfly Valve Installation Instructions above prior to completion of the electrical hook-up of the Electro-Thermal Actuator.
- B) The ETL is designed to react to an electrical impulse of 0.2 amps over a short period of time (less than 1 millisecond) at a voltage range of 6-30 volts AC or DC low voltage NEC Class 2. Power may be taken from a low voltage Class 2 source (found on most smoke detectors) and switched through any appropriately rated normally open set of contacts in the detector, so that the ETL will be impulsed upon detection of smoke. Similar circuitry may be used with rate of rise detectors or any normally open manual or automatic alarm switch.
1. The wiring is subject to the National Electrical Code Par. 300-22, which requires the use of metallic protection of all such wirings. Accordingly, the ETL has the same diameter on the wire end as ½" electrical metallic tubing (EMT) permitting standard, UL listed connectors, either 3/8" flex to ½" EMT, or ½" EMT to ½" EMT to be used, together with the appropriate flexible conduit, to completely encase the wires in metal.
  2. Prior to making the final wiring connection, energize the power source and check for proper voltage with a Voltmeter. At the same time an Ohmmeter with output not to exceed 10 milli-amperes should be connected to the leads of the ETL to test for continuity. If the resistance is not within 10 to 30 ohms, remove the Actuator and return it or exchange.

#### **WARNINGS/CAUTIONS**

- **Be sure the circuit is de-energized before connecting the ETL leads to the power source.**
- **Most detectors send out a low power battery signal. When battery voltage becomes weak, this signal may activate the Valve unless detector is of the type that allows for this condition without the sending a low power signal.**
- **Warranty is voided if ETL is used in monitored systems with more than an absolutely limited one (1) milli-ampere maximum input constant current.**

## 6. ACTUATOR REPLACEMENT INSTRUCTIONS

**Note:** Actuators cannot be reset in the field. The Actuator must be returned to Essex Industries to be reset.

### **WARNINGS/CAUTIONS**

- **For all of the following Actuator Replacement Instructions, the Safety Pin is to be installed on the Actuator while performing this procedure.**

### **6.1. TO REMOVE THE ENTIRE ACTUATOR / BALL VALVE ASSEMBLY**

**Note:** This procedure cannot be performed on an Actuator / Butterfly Valve Assembly. The Actuator has to be removed from the Butterfly Valve prior to removing Butterfly Valve.

1. Install the Safety Pin onto the Actuator.
2. Using the removable Wrench, close the Valve.
3. Remove Valve from installation.

### **6.2. TO REMOVE A FIRED ACTUATOR FROM BALL OR BUTTERFLY VALVE**

1. Install the Safety Pin onto the Actuator.
1. Loosen all four (4) Whiz Lock® screws until the lead threads on all of the screws are flush with the bottom of the Bracket.
2. Carefully pry the Actuator up until a “pop” is heard which signals that the spring tension is relieved.
3. Proceed with removing the Whiz Lock® screws and Actuator completely off of the Bracket and Stem Coupler.

### **6.3. TO REMOVE AN UN-FIRED ACTUATOR FROM BALL OR BUTTERFLY VALVE**

1. Install the Safety Pin onto the Actuator.
2. Loosen all four (4) Whiz Lock® screws until the lead threads on all of the screws are flush with the bottom of the Bracket.
3. Carefully pry the Actuator up. If the unit has not been fired, a “pop” will not be heard. If the unit has been fired, a “pop” is heard which signals that the spring tension is relieved.

4. Proceed with removing the Whiz Lock® screws and Actuator completely off of the Bracket and Stem Coupler.

#### 6.4. TO REPLACE A LOADED ACTUATOR ONTO A BALL VALVE

1. Install the Safety Pin onto the Actuator.
2. Apply Molykote brand G-N Paste or equivalent to the: top and pins of the Stem Coupler mounted on Valve Stem; and bottom and slotted areas of the Lower Coupler on Actuator.

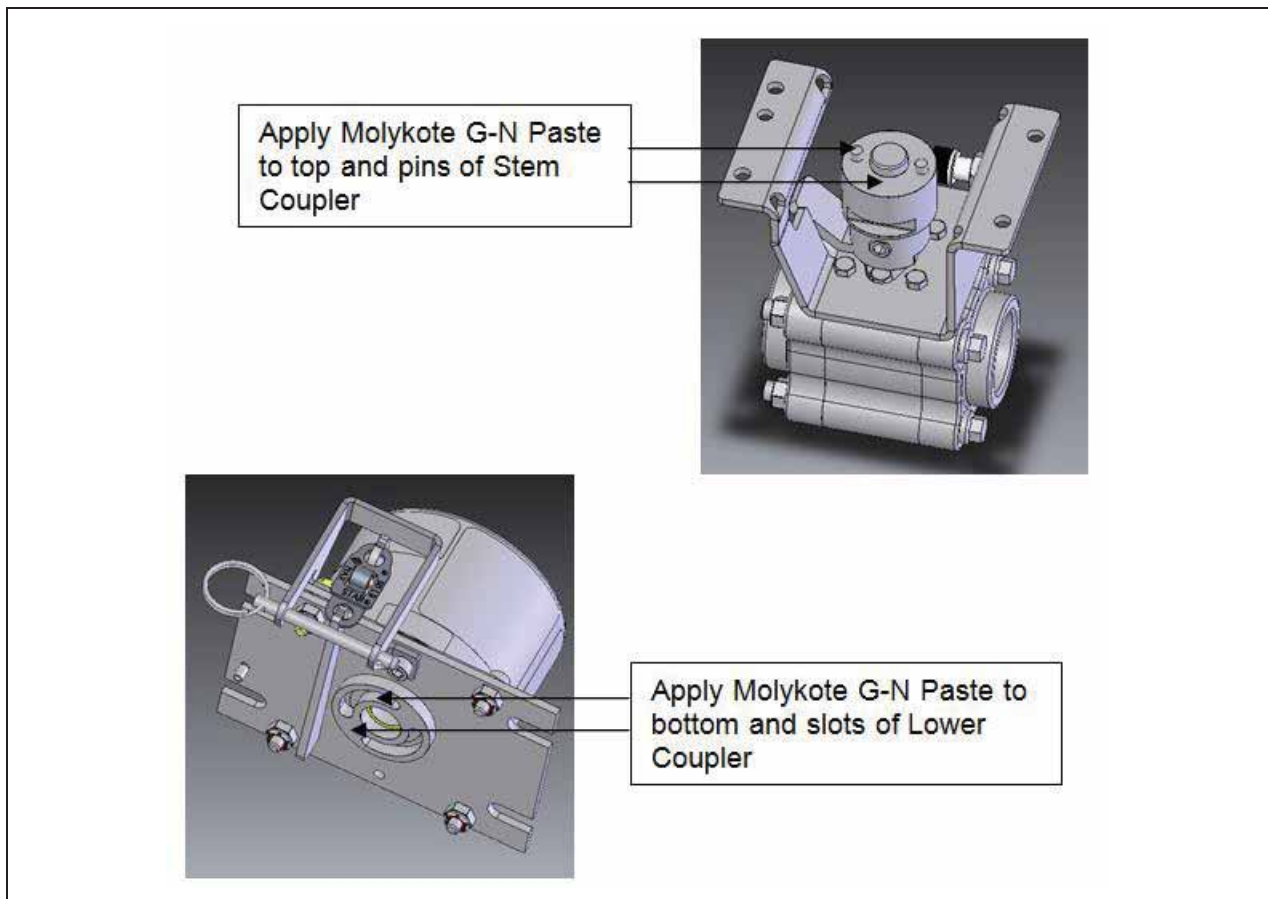

Figure 7 - Applying Molykote

3. Place the Actuator on top of the Bracket so the Pop Rivet on the Actuator engages with the mating hole in the Bracket.
4. Secure the Actuator to the Bracket using four (4) Whiz Lock® brand screws, torqued at  $250 \pm 12$  in-lbs. The use of this fastener is critical and a substitute should not be used.

**Note: There should be a minimal gap between Couplers when Whiz Lock® screws are tightened down.**

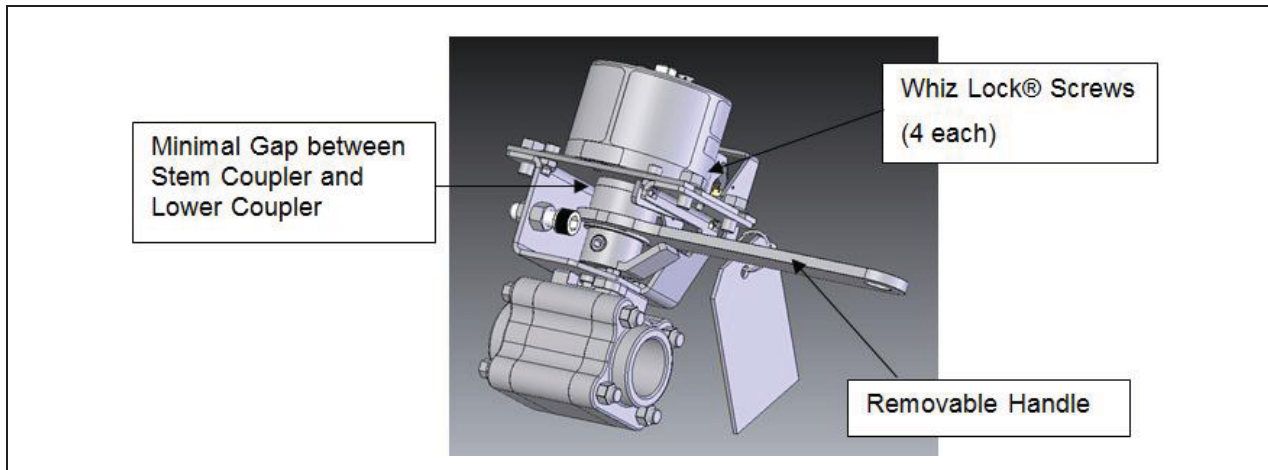

Figure 8 - Assembled Actuator on Valve

5. After installation, open and close Valve several times using removable Handle, to be sure that it operates smoothly.

**Note:** Like any quarter-turn Valve, the Thermal Shut-off Valve should be operated by the removable Handle periodically to prevent sticking due to corrosion, freezing, etc., to assure smooth operation or firing during the life of the Valve.

### **WARNINGS/CAUTIONS**

- **At no time should the removable Handle be left in the Valve after manually operating (to and open or closed position).**
- **Valve is quick-acting with closing/opening speeds recorded of less than one (1) millisecond.**
- **Store unit in an area where temperatures remain below 120° F (49° C).**
- **Remove the Safety Pin as noted on the Warning Ribbon when the Valve is put into operation. The Actuator will not operate with the Safety Pin in place.**

## **6.5. TO REPLACE A LOADED ACTUATOR ONTO A BUTTERFLY VALVE**

1. Follow steps detailed in 4. Thermal Actuator / Butterfly Valve Installation Instructions.

## 7. LIMITED WARRANTY

Essex Industries, Inc. (referred to in this warranty as "Essex") hereby warrants that the fire -safe valve and actuator assembly manufactured by Essex (the "Equipment") will be free from defects in material and workmanship, whether patent or latent. Upon timely written notice of any such defect and return of the applicable Equipment to Essex at 4150 Carr Lane Court, St. Louis, Missouri, 63119, transportation paid, Essex will correct such defect by repairing or replacing the applicable Equipment, at the sole discretion of Essex. The obligation to repair or replace any Equipment furnished hereunder shall terminate on the earlier of (i) six (6) months from the date on which such Equipment is initially installed within any application assembly, or (ii) twelve (12) months from the date on which such Equipment is shipped by Essex to the initial purchaser thereof. This warranty is Essex's sole warranty relating to the Equipment and is in lieu of all other warranties and representations, expressed or implied.

Purchaser's exclusive remedy against Essex shall be set forth above. In no event shall Essex be liable to purchaser for consequential, indirect, punitive, exemplary or special damages including, but not limited to, loss of or damage to any other equipment or any plant or facilities, loss of profit or any other damage arising out of the loss of use of the Equipment, any other equipment, or plant or facilities or loss of production, regardless whether the claim for such consequential damages be based on warranty (expressed or implied), contract, tort or otherwise. Nor shall Essex be liable to indemnify purchaser against any claims made against purchaser for such consequential, indirect, punitive, exemplary or special damages. Purchase agrees to defend, indemnify and hold Essex harmless from all claims (including claims for indemnity) for any such consequential, indirect, punitive, exemplary or special damages brought against Essex.

Essex shall not be responsible for any Equipment which has been repaired, worked upon or altered by persons not authorized by Essex, or Equipment, which has been subject to misuse, neglect or accident.

**THE FOREGOING WARRANTIES ARE IN LIEU OF ALL WARRANTIES, EITHER EXPRESSED OR IMPLIED, INCLUDING, BUT NOT LIMITED TO, ANY IMPLIED WARRANTY OF MERCHANTABILITY, NON-INFRINGEMENT, OR FITNESS FOR A PARTICULAR PURPOSE, AND OF ANY OTHER OBLIGATION ON THE PART OF ESSEX EACH OF WHICH IS HEREBY EXCLUDED AND DISCLAIMED BY ESSEX.**



Customer Service / Technical Service: 1-800-899-0553