

# P5/E5



## IOM Instructions

# Contents

---

<b>1. Introduction</b>	<b>4</b>
<b>2. Storage instructions</b>	<b>6</b>
PMV Positioner and feedback module storage and handling procedures	6
Warehouse storage	6
Field storage	6
Pneumatic positioners	6
Potential damage mechanism	6
Storage Seal (P5/E5)	7
<b>3. Function</b>	<b>8</b>
<b>4. Installation</b>	<b>9</b>
Air requirements	9
Installation	9
<b>5. Connections</b>	<b>10</b>
<b>6. Cam adjustment</b>	<b>12</b>
<b>7. Calibration</b>	<b>13</b>
Calibration procedure	13
<b>8. Indicator adjustment</b>	<b>14</b>
<b>9. Front cover and indicator cover</b>	<b>14</b>
<b>10. Dampers</b>	<b>15</b>
<b>11. I/P Unit (P5/E5)</b>	<b>16</b>
<b>12. How to mount the I/P Unit to the positioner unit (P5/E5)</b>	<b>17</b>
<b>13. Maintenance</b>	<b>18</b>
Pilot valve	18
Diaphragm	19
Feedback spring	20
Balance arm	20
Lower arm	21
O-rings	22
Filter plug (E5)	22
<b>14. Feedback unit (P5 or E5)</b>	<b>23</b>
<b>15. Trouble shooting</b>	<b>24</b>
<b>16. Technical data</b>	<b>25</b>
<b>17. Spare parts, P5/E5</b>	<b>30</b>
<b>18. Certificates</b>	<b>34</b>

Manufacturers declaration • Hersteller-Erklärung • Déclaration de fabricant

## **G B**

### **Manufacturers declaration**

in compliance with EC directive 89/ 392/ EEC, annex I I B and 89/ 336/ EEC.

We hereby confirm that the appliances described in this sheet has been manufactured in compliance with the applicable standards and is intended for installation in a machine/ application, and that commissioning is strictly prohibited until evidence has been provided that the machine/ application in question is also in compliance with EC directive 89/ 392/ EEC and 89/ 336/ EEC.

This manufacturers declaration is applicable to the following PMV-Positioner series:  
P5, E5, F5.

## **D**

### **Herstel ler-Erkärung**

im sinne der EG-richtlinie 89/ 392/ EWG, A nhang I I B und 89/ 336/ EWG.

H iermit erklären wir, daß die in diesem Blatt beschriebenen Geräte entsprechend den gültigen Normen gebaut und zum Einbau in eine Maschine oder Applikation bestimmt sind, sowie daß deren Inbetriebnahme so lange untersagt ist, bis festgestellt wurde, daß diese Maschine/Applikation ebenfalls der EG-Richtlinie 89/ 392/ EWG und 89/ 336/ EWG entspricht. Diese H erstellererklärung hat für folgende PMV-Stellungsregler-Serien  
Gültigkeit:  
P5, E5, F5.

## **F**

### **Déclaration de fabricant**

au sens dela directive de la CE 89/ 392/ CEE, annexe I I B et CE/ 89/ 336/ CEE.

N ous déclarons par la présente que les appareils décrits sur cette page sont construits en conformité avec les normes en vigueur et qu'ils sont destinés à être montés dans une machine ou une application, nous déclarons également que leur mise en service est interdite tant qu'il n'a pas été constaté que cette machine/application satisfait également à la directive CE 89/ 392 CEE et CE/ 89/ 336/ CEE.

Cette déclaration de fournisseur est valable pour les types d'appareils PMV suivants:  
P5, E5, F5.

Mr. Roland Wedebrand  
President, Palmstiernas Instrument AB

### **Special Conditions for Safe Use**

The enclosure is made of aluminium and any impact or friction caused by external objects shall be avoided in the application.

Rubbing of the window with dry fabrics shall be avoided when the positioner is used in an hazardous atmosphere in order to avoid potentially incendive static discharges.

# **1. Introduction**

---

## P5

The base unit of the system is the pneumatic positioner, used in either single or double acting applications. P5 comes standard with built in dampers, a high gain spool valve assembly, gauge ports and an O-ring sealed housing. The housing utilizes a unique O-ring seal that can be adjusted to a sealed or drained position.

The modular design concept allows for easy addition of accessories such as I/P converter and/or a feedback package, both which are isolated from the basic pneumatic unit. These accessories can be factory or field mounted.

Ease of calibration and maintenance are built into the design with easily accessible span and zero adjustment, and very simple parts replacement.

ATEX:  II 2 GD

## E5

The E5 has same features and benefits as the P5 positioner. It's modular to suit several applications, General applications, intrinsically safe, explosion proof and fail freeze versions are offered.

Intrinsically Safe: ATEX: EEX ia IIC T4  II 1 GD  
CSA, FM Class I, Div, Group ABCD

Explosion proof: ATEX: EEX d IIB+H<sub>2</sub>, T4-T6  II 2 GD  
CSA, FM Div I, Class 1,2 & 3 Group BCDEFG

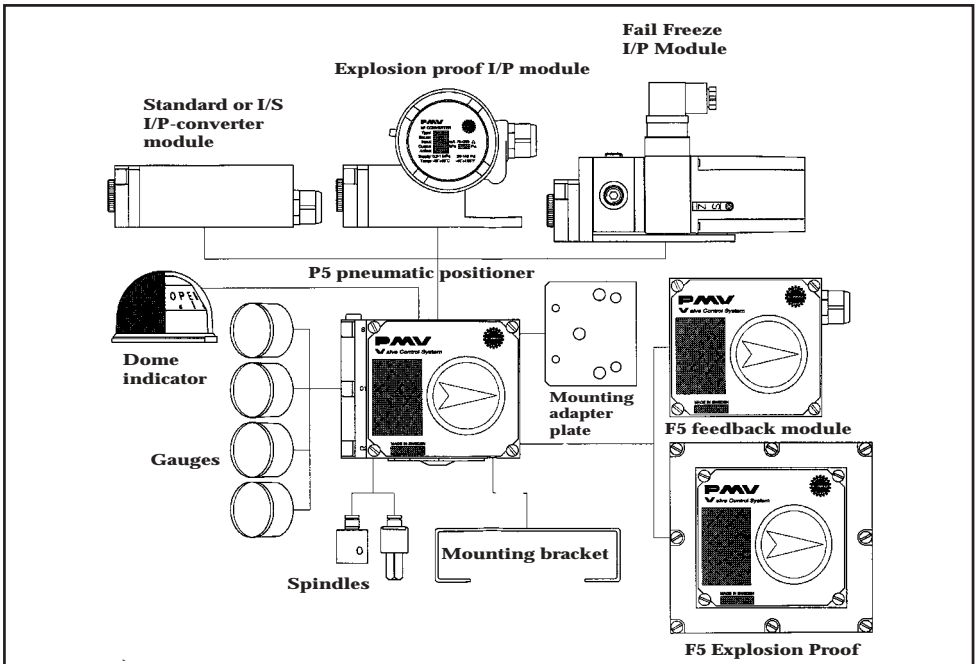

## 2. Storage instructions

---

### **PMV Positioner and feedback module storage and handling procedures**

PMV Positioners and feedback modules are precision instruments which should be stored and handled accordingly to avoid problems or damage.

Electropneumatic positioners/feedback modules contain electronic components which can be damaged by exposure to water. Appropriate precautions should be taken to protect units while in storage.

### **Warehouse storage**

Stored in original PMV shipping containers, units should be stored in an environmentally controlled area, i.e. clean, cool (15-26°C, 60-80°F) and dry, out of direct sunlight or weather exposure.

### **Field storage**

**Note:** Once the air supply to the positioner is connected and turned on, internal air bleed will prevent the ingress of moisture and protect the unit from corrosion. It is recommended that the air supply be left on at all times.

- If units are installed immediately, turn, and leave on, the air supply.
- If positioners must be stored outdoors, tighten all covers which may have loosened in shipment, make sure all open enclosure entry points are sealed.

Feedback modules should have cover tightened and conduits entries sealed. Positioners/ Feedback modules should be wrapped and sealed air and watertight with desiccant inside the plastic, units should be securely covered with an opaque cover and not exposed to direct sunlight, rain or snow.

### **Pneumatic positioners**

Units should have all ports sealed and be protected from direct exposure to weather. For long term storage (>1 month) or overseas shipment units should be protected with plastic and desiccant.

### **Potential damage mechanism**

When units are stored in hot, humid climates, the daily heating/cooling cycle will cause air to expand/contract and be drawn in and out of the positioner/feedback housing.

Dependent on the local temperature variations, humidity and dew points and time in storage condensation could occur and accumulate inside on the I/P Converter causing erratic operation or failure due to water and corrosion. The potential for condensation damage is especially high in southern climates and aggravated if units are exposed to direct sunlight.

**For further assistance, please contact you nearest PMV office.**

## Storage Seal (P5/E5)

P5/E5 is supplied with all enclosure entry points sealed. The seal is only a storage seal, not to be used as seal when P5/E5 is in operation. If Storage Seal is removed or damaged, make sure all open enclosure entry points are proper resealed before further shipping or storage.

Use circular stickers marked **I**, **S** and **OUT**, supplied on Storage Seal or vapour proof tape.

### P5

Remove Storage Seal from connection block, mount positioner on actuator/valve, make connections according to section 5, (Page 10). Calibrate span and Zero according to section 7, (Page 13).

Clean any oil/debris off the connecting block, then reseal open enclosure entry ports, use circular stickers marked **I**, **S** and **OUT**, supplied on Storage Seal or vapour proof tape.

### E5

Follow P5 instructions as above. Remove Storage Seal for conduit entry **IE**, connect input signal cable and install proper cable gland to secure the units sealing.

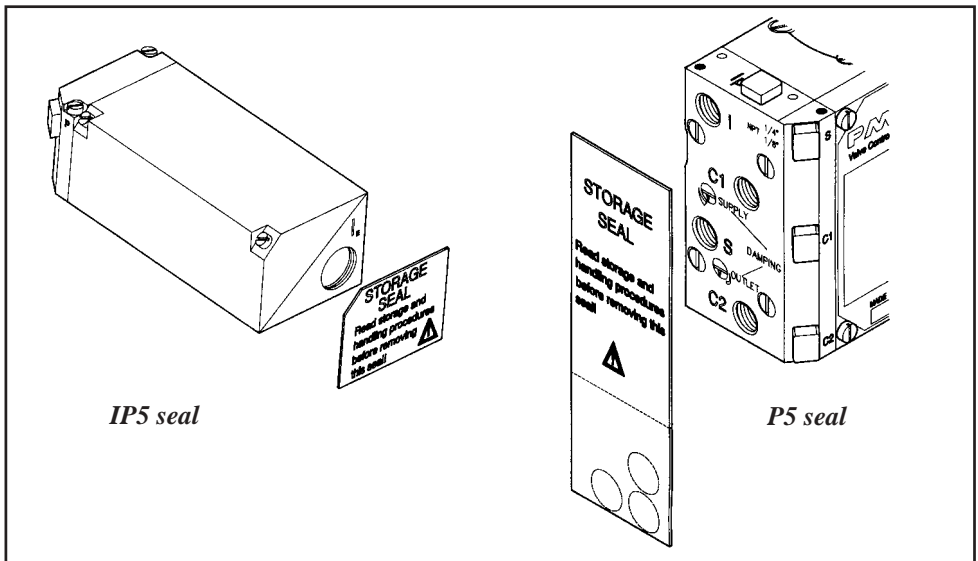

### 3. Function

The P5 and E5 operates on a force balance principal. Force is originated by the signal pressure transmitted through a diaphragm on to the balance arm. The opposing force is achieved through the feedback spring and is proportional to the position of the lower arm.

The lower arm position is determined by the position of the cam which is secured to the spindle and connected to the actuator shaft thus providing the feedback from the actuator/valve. When these two forces are equal, the balance arm and the spool in the pilot valve are in a neutral position — the complete unit is in a balanced position. Air is supplied to the pilot valve through port S, and controls the air flow through ports C1 and C2

**Assume an equilibrium position.**

An increased control pressure will deflect the diaphragm **1** down, compressing the feedback spring **3**. The balance arm **2** moves the spool **7** in the pilot valve **8** furnishing supply air to the actuator, while at the same time air is exhausted from actuator and is vented to atmosphere through the pilot valve and the OUT port . With the increased supply air, the actuator rotates (or moves linearly) moving the positioner spindle **6**. The spindle and cam **5** rotate, forcing the lower arm **4** upwards compressing the feedback spring **3**. This motion will continue until the two forces are equal and the unit is in an equilibrium position.

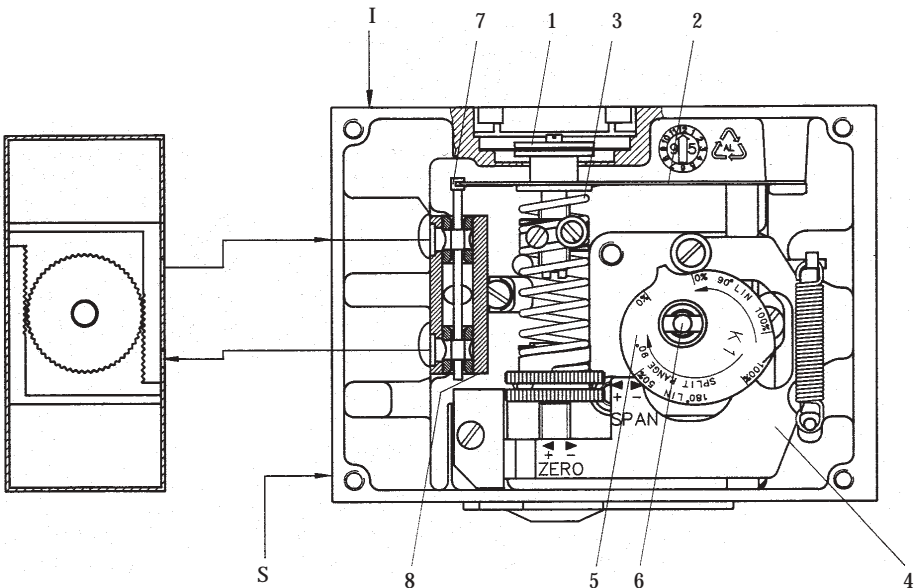



## 4. Installation

---

### Air requirements

Maximum supply pressure is 1 MPa (150 psi). Supply air shall be clean, dry and free from oil, water, moisture, foreign parts and debris.

The air shall be freeze-dried or similar to a dew point of at least 10°C (18°F) below lowest expected ambient temperature.

A <40µ filter/regulator is recommended to be installed as close to P5/E5 as possible to ensure proper supply air quality.

Before making pneumatic connections to the positioner, it is recommended that the supply air lines are opened up and allowed to vent for 2-3 minutes to clear any debris from the line. It is further recommended that a large paper bag is used to collect any oil or humidity that may be present in the line during this purging, direct the air flow into the bag. Should excessive amounts of oil and/or humidity be present at this stage, a review of the pneumatic system should be carried out and the problem corrected.

**Poor air quality is one of the major causes of premature failure of pneumatic equipment.**

### Installation

P5 and E5 mounts on to the actuator using either the ISO F05 holes **4** and a PMV ISO mounting kit or by using the optional mounting adaptor and screws **5** to mount P5 on to existing PMV mounting kits.

Proper alignment of the positioner spindle to the actuator shaft is very important since improper alignment can cause excessive wear and friction to the positioner.

### P5/E5 only

The spindle/positioner shaft assembly allows for quick and simple spindle changes. To ensure the proper connection, the spindle **3** has a spring clip **2** that must be properly installed. A solid "click" should be felt when assembling the two pieces insuring that the two flats **1** are engaged into the positioner shaft groove.

The spindle can be removed, by inserting two screwdrivers under the two tapered surfaces of the spindle and bending carefully. When the spring clip releases the spindle will eject.

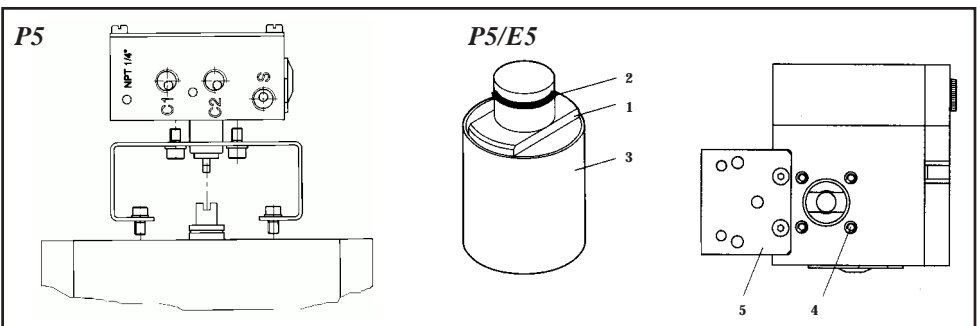

# 5. Connections

Air connections are tapped for 1/4" G or NPT male connectors and are clearly marked.

Gauge ports are for 1/8" G or NPT.

We recommend use of Loctite® 577 or similar user preferred for sealing.

Electrical connection on I/P unit accepts 1/2" NPT or PG 13,5 (M20) cable gland.

**Port I** Input instrument pneumatic signal 20-100kPa (3-15 psi)

**Port S** Supply air, maximum 1 MPa (150 psi) Minimum 0,15 MPa (21 psi) for E5

**Port C1, C2** Actuator connections (0,2-1 MPa). C2 opening port.

For single acting operation plug port **C1** for increasing signal to open valve. Plug **C2** for decreasing (reverse) signal to open valve.

**OUT** Exhaust air port. **Do not block!** Exhaust filter optional.

**Port Ip** Gauge port for pneumatic input signal.

**Port I<sub>E</sub>** Input electric signal (4-20 mA) (On the I/P unit.)

**Port P** Gauge port for I/P unit output pressure ( On the I/P unit)

*P5/E5 only*

Ports **Ip**, **P**, **S**, **C1** and **C2** are sealed with plugs. To install gauges, unscrew plugs and replace with gauges.

Port **OUT** is for venting the unit. All air from the positioner, actuator and I/P unit is vented to atmosphere through this port. **Do not block this port.** A high flow silencer or an exhaust pipe can be connected to this port to prevent foreign objects from entering and blocking the units exhaust. Connector in exhaust port must not have less than 9 mm (3/8") orifice.

When using gases other than air for supply — Please contact PMV.

On E5 (P5 with I/P unit installed) I/P unit is supplied with air from port **S**. Port **I** is automatically sealed off and protected. No connection shall be made to this port. See pages 13 and 14 for more information.

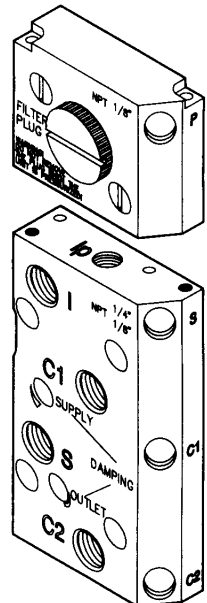

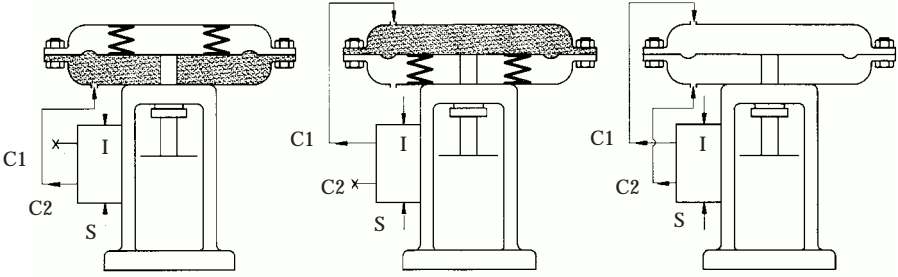

X = Port plugged

## Direct function

Direct function  
Air to open

Reverse function  
Air to close

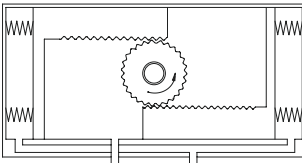

Spring  
Return

PLUG C1

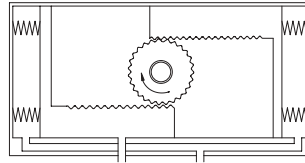

PLUG C2

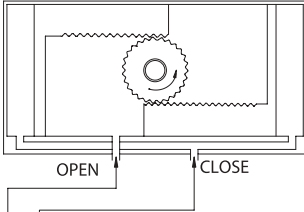

Double  
acting

OPEN CLOSE

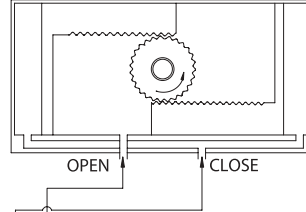

OPEN CLOSE

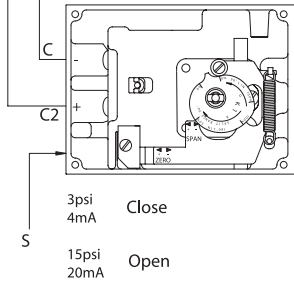

3psi  
4mA Close  
15psi  
20mA Open

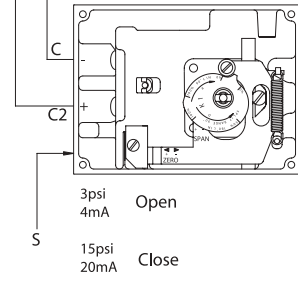

3psi  
4mA Open  
15psi  
20mA Close

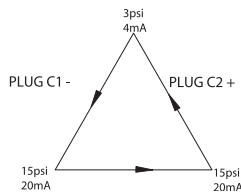

Signal/connection  
Spring return actuator

## 6. Cam adjustment

With the cover and indicator removed, loosen the screw **1** and turn the cam locking nut **2** counterclockwise until the cam loosens. Adjust the cam **3** as desired making sure that the ball bearing **4** always is riding on an active lobe on the cam. To secure the cam, make sure that screw **1** is backed out from the locking nut **2** then finger tighten the locking nut and tighten screw **1**. Install and adjust the indicator and reinstall cover.

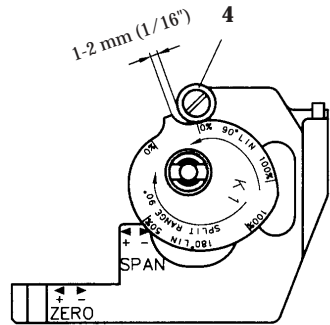
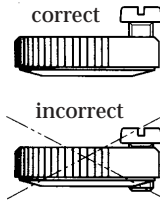
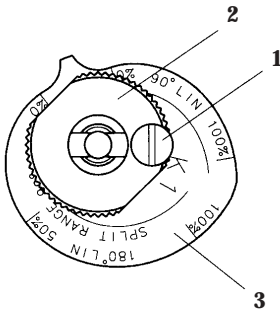

# 7. Calibration

P5/E5 is when shipped from PMV pre-calibrated for  $90 \pm 0,5$  deg rotation, (can also be 30, 45 or 60 deg, see installed cam). For most applications the valve closed position is more critical than valve open position, most attention should be paid at valve closed position. Always start calibration procedure by applying 0 % input signal, then adjusting zero. P5/E5 is calibrated by turning thumb wheels **1** & **4**.

Arrows on arm **5** indicate turning direction of thumb wheels.

< “+“ = Increase zero/span

> “-“ = Decrease zero/span

## Calibration procedure

Check cam seating, section 6 before starting calibration procedure.

1. Apply 0 % input signal (0% = 20 kPa/3 psi or 4 mA)
2. Wait for steady state.
3. Adjust zero by turning the silver (lower) thumb wheel **4** with finger or with screwdriver **7** from the outside.
4. Apply 100% input signal (100% = 100 kPa/ 15 psi or 20 mA)
5. Wait for steady state then memorize result.
6. Apply 0% input signal.
7. Adjust span if necessary. This is done by first loosening screw **2**, then turning the yellow (upper) thumb wheel **1** “+“ or “-“ and finally tightening screw **2**. Spring top must not be in contact with spring guide **3**.
8. Check zero and adjust if needed.
9. Repeat steps 2 to 8 until desired calibration is achieved.

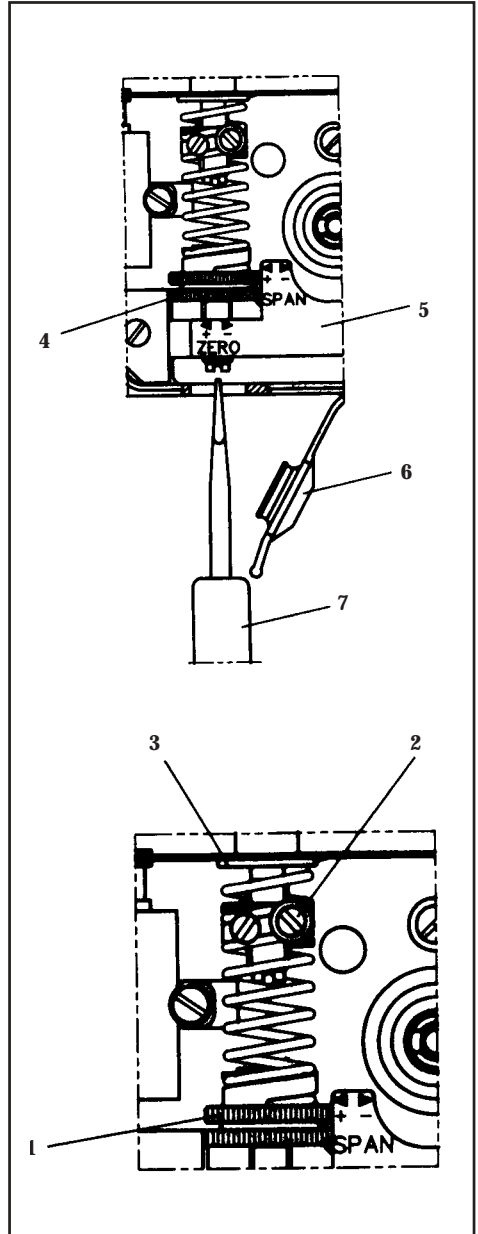

## 8. Indicator adjustment

---

**P5/E5:** To adjust the indicator, take off front cover and pull the indicator upwards until it comes off the Allen screw.

Before installing the indicator make sure that the Allen screw is tightened. Press the indicator on the screw and adjust it by rotating clockwise to desired position.

## 9. Front cover and indicator cover

---

The front cover of P5 is secured to the pneumatic unit with four captured screws and sealed with an O-ring **1**. The O-ring can be looped over notches **2** in the front cover to allow for drainage. There are eight locations on the front cover where the O-ring can be looped. This O-ring system is common to the Pneumatic unit, I/P unit and Feedback unit in the PMV Valve Control System P5. This unique sealing system allows for complete sealing or draining of the units by changing the position of the O-ring.

The indicator cover **3** is O-ring sealed and secured by a bayonet coupling. The indicator cover is also used to secure the identification cover **4**.

To remove the indicator cover turn it slightly counterclockwise until it loosens. Identification cover and O-ring **5** are now removable.

When installing indicator cover and identification cover make sure that the O-ring is properly engaged.

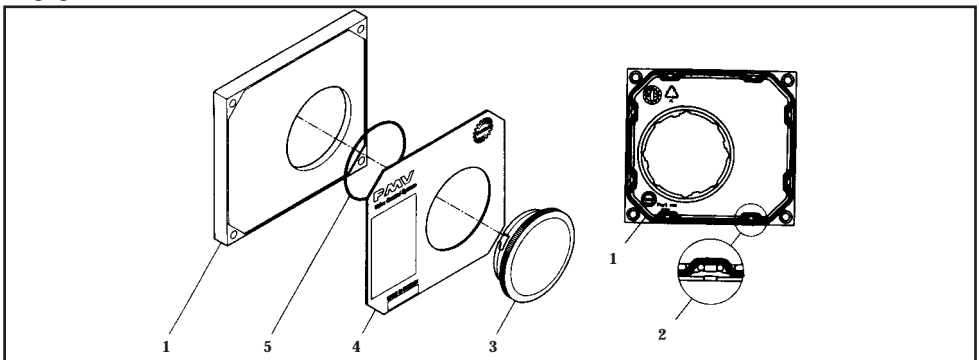

# 10. Dampers (P5/E5)

---

The standard built in dampers **5** located on the connecting block provide a simple means of adjusting the actuator travel speed.

For maximum actuator travel speed dampers shall be adjusted to minimum damping position. (Fig).

**Double acting actuators** – adjust only **OUTLET** damper, set **SUPPLY** damper in minimum damping position.

**Single acting actuators** – adjust both dampers for desired operation.

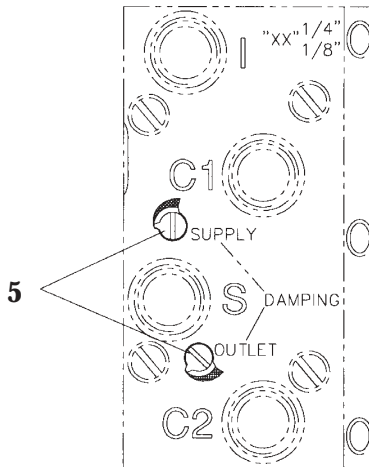

## 11. I/P Unit (P5/E5)

**WARNING! Units installed in hazardous areas must have proper approvals.**

The I/P unit is mounted directly on top of the positioner unit.

No external air supply is needed since the I/P unit is supplied with air from the positioner unit.

Port I on the positioner unit will be plugged when the I/P unit and the appropriate gauge block gasket installed. The I/P unit accepts a 4-20 mA input signal.

The I/P unit is equipped with a built in 30 micron filter (Fig 4).

**Caution:** Do not operate the unit without filter and filterplug installed. Ensure that wiring between I/P and terminals are properly seated in rubber clamp.

Do not unscrew filterplug when the positioner is pressurized.

Span and Zero for the I/P converter is factory set and can not be adjusted

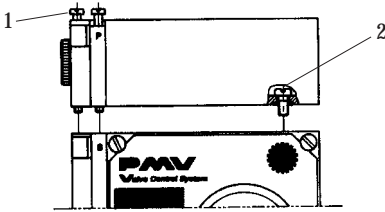

Fig 1



Fig 2

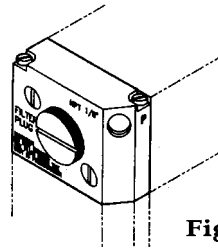

Fig 4

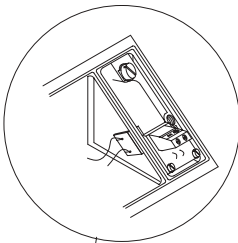

Fig 3

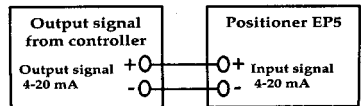

Fig 5

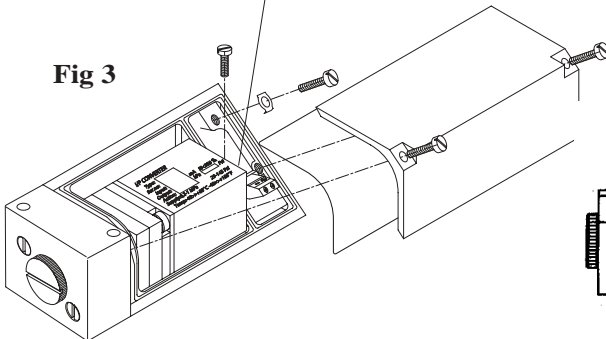

Fig 6



## 12. How to mount the I/P Unit to the positioner unit (P5/E5)

Switch off supply air and disconnect input signal – port **I**.

Loosen screws **3** and remove connection block **1**, the gauge or plug from port **I<sub>p</sub>**, the fitting from port **I** and existing gasket **4**. Carefully install gasket **6** supplied together with I/P unit. When correct installed port **I** will be blocked by the gasket.

Make sure that relief valve spring **5** is installed properly. Install the connection block **1** to the positioner unit **2**.

Remove cover on I/P unit.

Install the I/P unit to the top of the Positioner unit, making sure that the four O-rings are present and properly seated. Tighten the unit with the three screws. (See fig. 1 and 2 page 16) Screw **1** first, screw **2** last.

**WARNING!** Units installed in hazardous areas must have proper approvals.

Connect input signal cable to port **I<sub>E</sub>** and tighten the cable gland (see fig 5 on page 16). Adjust the O-ring on the I/P Unit housing to desired position - sealed or drained. (See fig 3 on page 16 or section 9 on page 14).

A gauge indicating output signal from the I/P converter can be installed in port **P**. Make sure that the filter plug is tightened before supply air is switched on (Fig 4 on page 16).

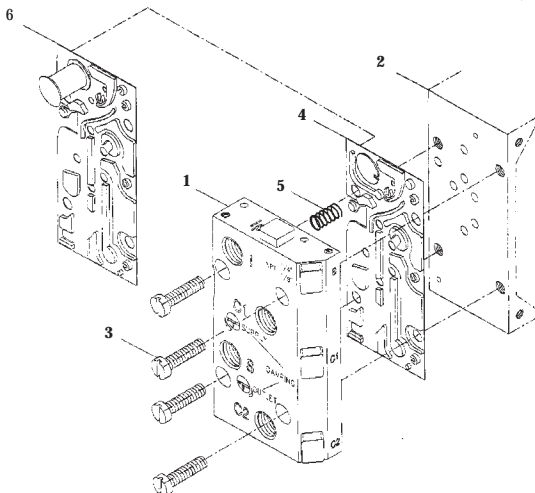

## 13. Maintenance

When upgrading electronically parts inside a PMV positioner approved for installation in Hazardous locations special procedures apply, permission from PMV is required prior to the start of work.



Please contact your local PMV Sales office for information regarding proper procedures.

[www.pmv.nu](http://www.pmv.nu) or [info@pmv.nu](mailto:info@pmv.nu)

### Pilot valve

To remove the pilot valve for cleaning or inspection, remove the screw **1** and carefully lift out the complete assembly **2**. Gently remove the spool **3** from the block and clean the parts, using methylene cleaner or similar. Blow the parts dry with compressed air. Install the spool into the pilot valve housing, place it on a flat surface, then lift it carefully in one end. Before reaching 20 deg angle the spool should slide by itself.

Should the parts show signs of wear, a new assembly is recommended. Mixing spool valves and valve bodies may result in very high bleed rates and poor performance. Check the O-rings, then secure and install the pilot valve assembly into positioner unit, press it towards the positioner housing wall and secure it with screw **1**. Make sure that the leaf spring **4** on the balance arm **5** is properly fitted in the groove on the spool **6**. Check again to insure smooth operation of the assembly.

To maintain original factory performance specifications, use only spool valve assemblies supplied by PMV.

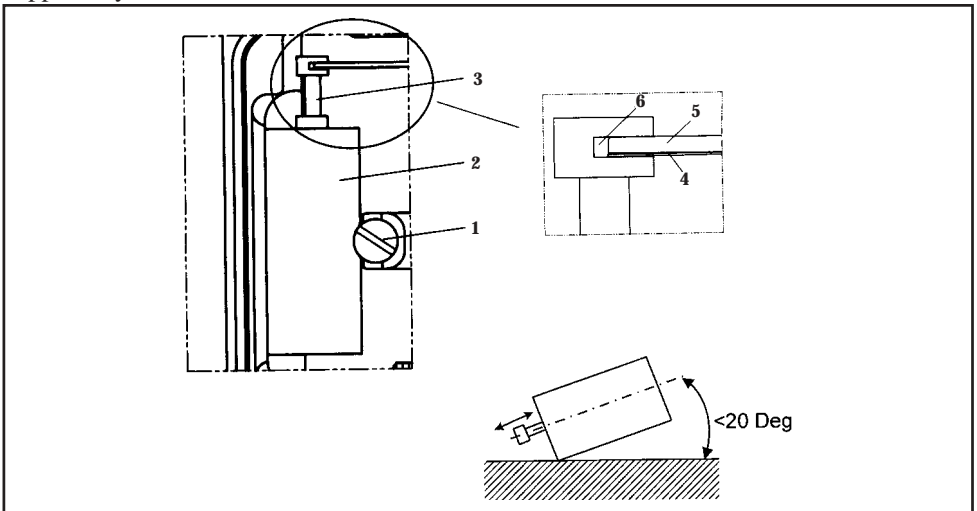

## Diaphragm

If P5 is equipped with I/P unit (E5), the I/P unit must be removed to access the diaphragm. When installing the diaphragm make sure to place one washer on each side of the diaphragm. Put some Loctite 577 on the thread, install the screw **3** and tighten.

Make sure the diaphragm is centered.

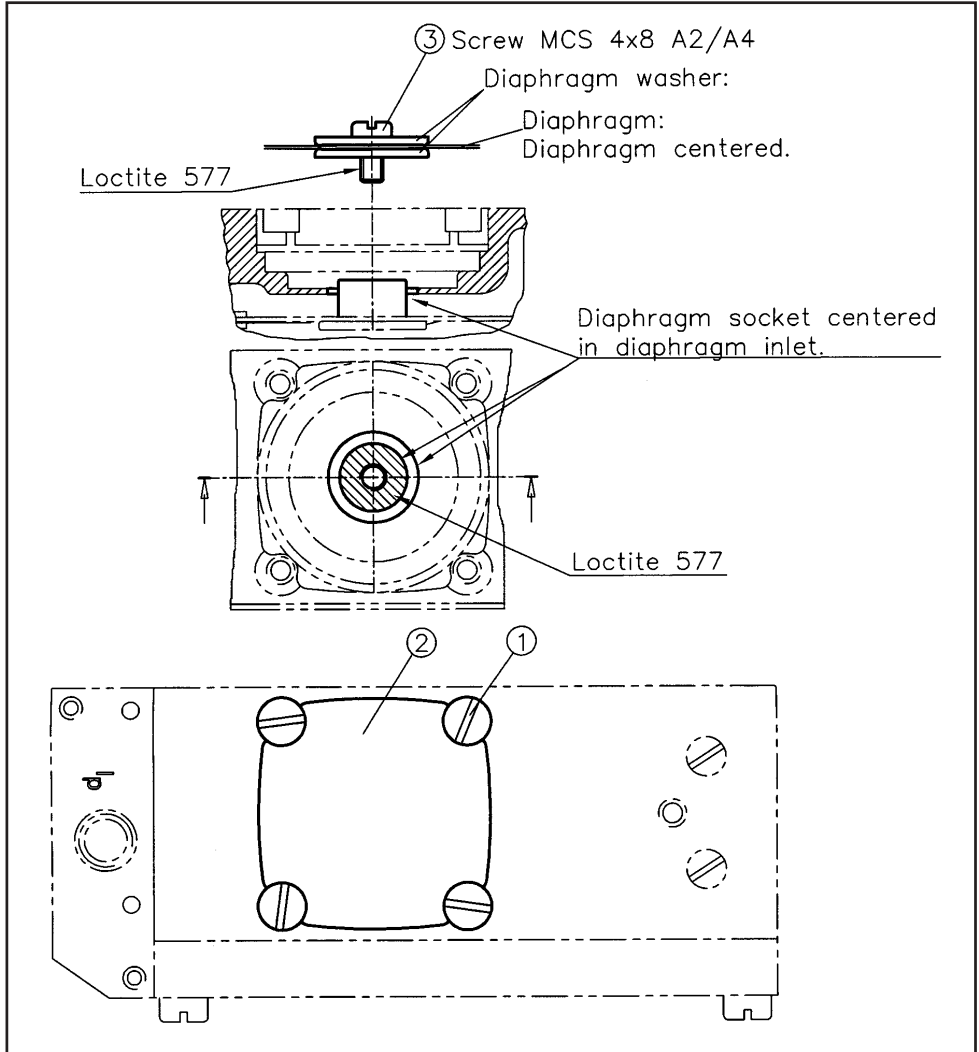

Check the O-ring for the diaphragm cover **2**, install the O-ring into the positioner housing, then install cover **2**. Secure crosswise with screws **1**, first turn loosely. Torque shall be 4,5 Nm (40 in-lbs).

## Feedback spring

Once the front cover and indicator are removed, the feedback spring can be easily accessed.

Hold the spring **1** from the top, pull down and out.

When installing, hold the assembly at the top, guide the lower part to position on the zero screw, then press down until it fits easily under the balance arm **2**. Make sure that the assembly is aligned properly against the lower arm and the notch is engaged in the tab on the balance arm **2**.

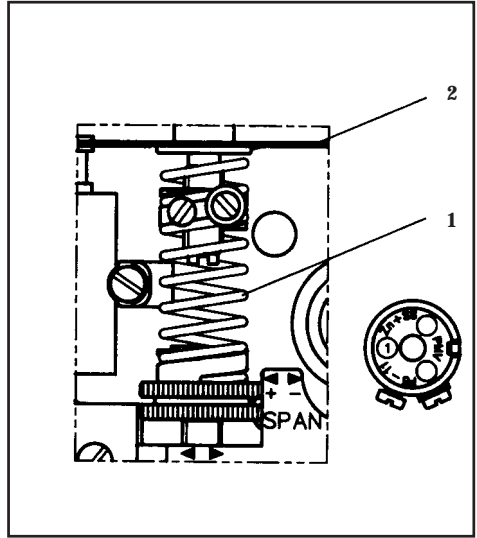

## Balance arm

The balance arm **3** can only be removed after I/P unit, diaphragm and feedback spring have been removed. (See sections above and on page 16, 18 and 19).

Loosen the screws **3** and the balance arm can be removed.

installing the balance arm make sure that the leafspring **4** on the underside of the balance arm **5** is properly engaged into the groove **6** of the spool in the pilot valve. Tighten the two screws **3** holding the balance arm to the positioner.

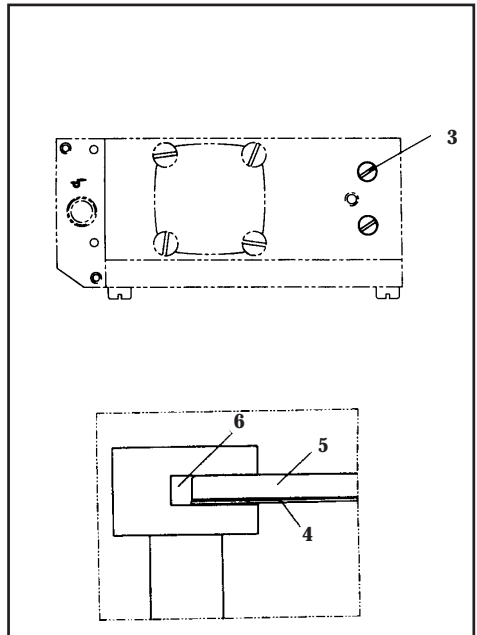

## Lower arm

Once the front cover is removed, the lower arm can be easily accessed.

Remove the indicator, feedback spring and the cam.

Loosen screw **2** and remove twist stop **1**.

Remove screw **3**, lower arm **4**, rod **5** and spring **6**.

Check rod and lower arm for wear, replace if necessary. Clean the rod and install it in the lower arm. The lower arm should move easily and smoothly.

Install the lower arm and rod assembly into the positioner housing, making sure that the spring **6** is attached properly to the lower arm and positioner housing.

Secure the lower arm and rod assembly with the screw **3**.

Check again that the lower arm moves smoothly.

Apply a small amount of grease on the small tongue on the lower arm, then install and secure the twist stop.

Install cam, feedback spring, indicator and front cover.

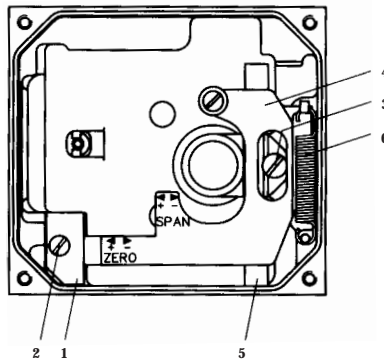

P5/E5

## O-rings

With time and use, O-rings can become brittle. This can cause poor operation and even failure of the positioner.

Always check O-rings when performing any work on the positioner and replace bad O-rings.

A thin layer of silicon grease applied on the NBR (Black) O-rings prolongs their life. On Q (red) O-rings, use a non silicon based grease.

## Filter plug (E5)

**Caution! Do not operate the unit without filter and filter plug installed. Do not attempt to unscrew filter plug while positioner is pressurized.**

E5 is equipped with a built in secondary filter located on the side of the I/P unit.

For replacement or inspection, make sure that positioner unit is not pressurized, then unscrew filter plug **1**. Remove filter **3** and install a new into the filter plug . Check condition of O-ring **2** and filter compartment. If moisture is found, check upstream filters/oil-water separators.

Moisture can cause I/P failure.

Reinstall filter plug.

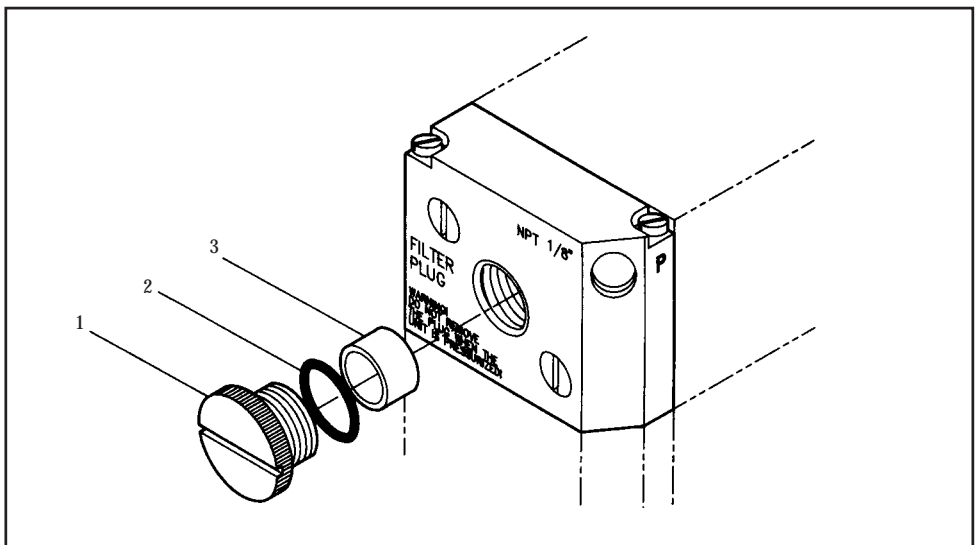

## 14. Feedback unit (P5 or E5)

See feedback module instructions for connections and calibration.

The P5 or E5, Valve Control System, can easily be equipped with a Feedback unit, model F5. This unit will mount directly on top of the Pneumatic positioner replacing the positioner front cover. The O-ring located on the bottom of the Feedback unit, F5, will provide the same sealing or draining capabilities as the front cover. The indicator and front cover from the positioner unit can then be installed on to the Feedback unit.

**WARNING! Units installed in hazardous locations must have proper approvals.**

Installing the feedback unit.

- Remove the front cover, indicator, and Allen head screw from the top of the positioner spindle.
- Install the drive coupling **4** and adjust the O-ring seal on the bottom in either sealed or draining position. (See section 6, page 10).
- Install the Feedback unit **9** on top of the Positioner unit, making sure the coupling is properly engaged before tightening the four screws **5**.
- Make electrical connections and tighten cable glands. (See F5 manual for details).
- Adjust cams and/or potentiometer to desired position.
- Install the indicator and front cover.

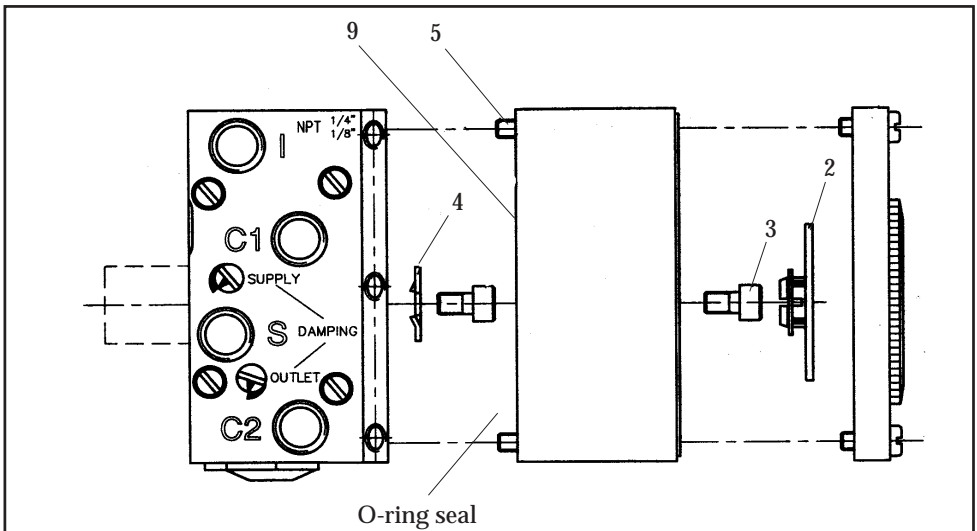

## 15. Trouble shooting

---

Note: All PMV-positioners are serialized. Please note down, and provide the serial number when contacting the factory for trouble shooting or service.

Signal change has no effect on the actuator position.

- Check indicator and screw.
- Check air supply to positioner and tubing to the actuator.
- Check input signal to positioner.
- Check diaphragm for damage or leakage.
- Check pilot valve function.
- Check cam for correct setting.
- Check I/P output

Signal change results in actuator running to end positions.

- Check coupling between positioner and actuator.
  - Check cam position and locking screw.
  - Check input signal.
- Inaccurate positioning.
- Dirty or worn pilot valve.
  - Defective or leaking diaphragm.
  - Input signal fluctuates.
  - Incorrect sizing of actuator.
  - Valve/actuator "stiction".
  - High valve/actuator breakaway torque.
  - Loose cam.



## 16. Technical data

---

	<b>P5</b>	<b>E5</b>
Input Signal	20-100 kPa/3-15 Psi (6-30 optional)	4-20 mA
Linearity	≤ 0,5% *	≤ 0,5% *
Hysteresis	≤ 0,75% *	≤ 0,5% *
Repeatability	≤ 0,5% *	≤ 0,5% *
Gain	(pressure 600 kPa/87 Psi) 1 000 (kPa/kPa) Min 66%/° ISA S75.13	
Air consumption at Supply pressure:		
0,2 MPa/29 Psi	5,4 nl/min 0.19 SCFM	6,1 nl/min 0.22 SCFM
0,4 MPa/58 Psi	12,3 nl/min 0.43 SCFM	13,6 nl/min 0.48 SCFM
0,6 MPa/87 Psi	20 nl/min 0.71 SCFM	22 nl/min 0.78 SCFM
0,8 MPa/116 Psi	27,8 nl/min 0.98 SCFM	30,5 nl/min 1.08 SCFM
1 MPa/145 Psi	35,7 nl/min 1.26 SCFM	39 nl/min 1.38 SCFM
Air delivery at Supply Pressure:		
0,2 MPa/29 Psi	200 nl/min 6.9 SCFM	
0,4 MPa/58 Psi	370 nl/min 12.8 SCFM	
0,6 MPa/87 Psi	540 nl/min 18.8 SCFM	
0,8 MPa/116 Psi	710 nl/min 24.7 SCFM	
1 MPa/145 Psi	880 nl/min 30.6 SCFM	
Supply Pressure Max 1 MPa/150 Psi		0,15-1 MPa/21,8-150 Psi
Temperature range	-20°C to +85°C (-4°F to 185°F)	
Connector threads	1/4" NPT or G	
Gauge threads	1/8" NPT or G	
Weight std.	1,1 kg/2.4 lbs	1,5 kg/3.4 lbs
Weight with gauges	1,3 kg/2.9 lbs	1,8 kg/3.9 lbs
Ingress protection		IP 66/NEMA 4

\* Per cent of full scale.

(The information in this manual is subject to change without notice.)

## Spare parts, P5/E5

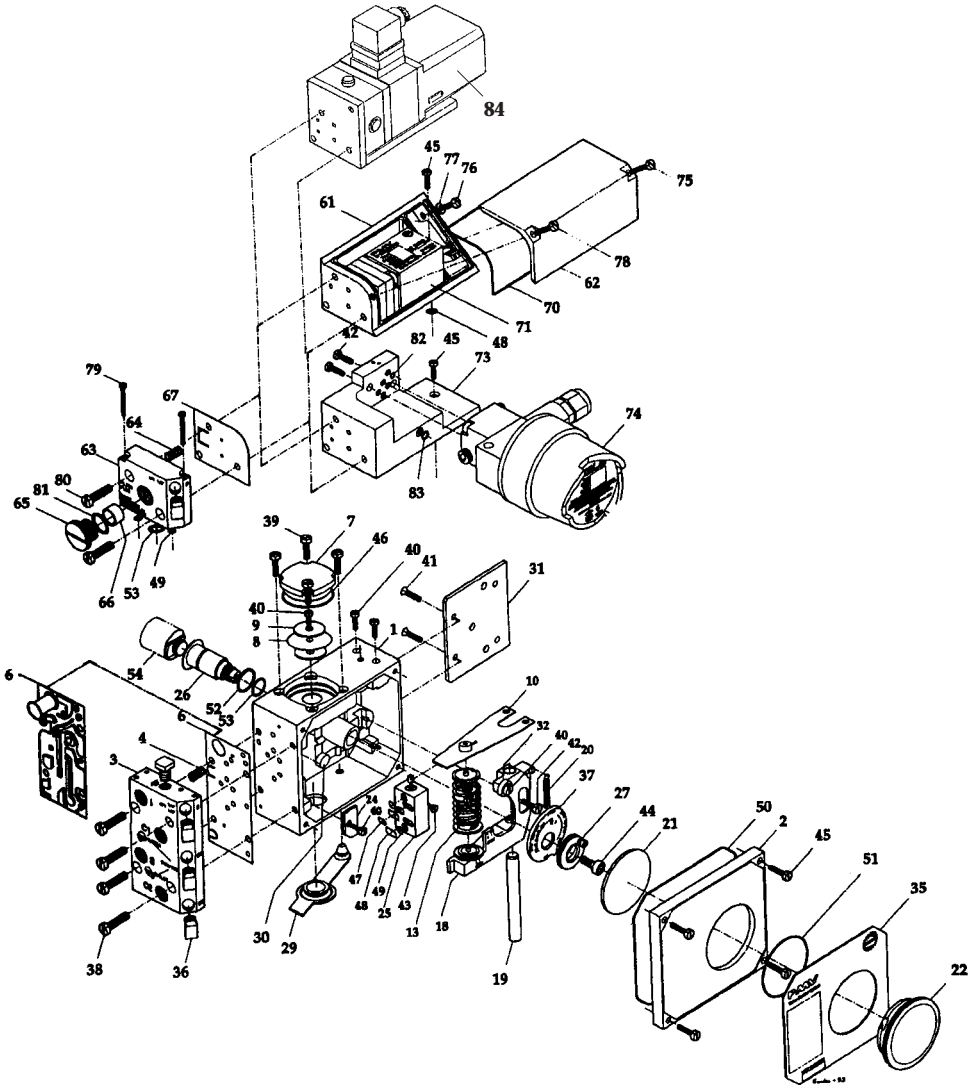

Pos	Part no	Qty	Description
1		1	Housing
2	P5-2	1	Front Cover incl. O-ring
3	P5-AS3N	1	Connecting block NPT 1/4" assembly
3	P5-AS3G	1	Connecting block G 1/4" assembly
4	P5-4	1	Relief valve spring
6	P5-6P	1	Gasket for P5
6	P5-6EP	1	Gasket for E5
7	P5-7	1	Diaphragm cover incl. O-ring
8	P5-8	1	Diaphragm
9	P5-9	2	Diaphragm washer
10	P5-10	1	Balance arm
13	P5-AS13/315	1	Feedback spring 3-15 psi assembly
13	P5-AS13/630	1	Feedback spring 6-30 psi assembly
18	P5-18	1	Lower arm assembly
19	P5-19	1	Rod
20	P5-20	1	Spring
21	P5-21A	1	Indicator Arrow
21	P5-21F	1	Indicator Flag
21	P5-21P	1	Indicator Pointer
22	P5-22T	1	Indicator cover Transparent incl. O-ring
22	P5-22F	1	Indicator cover Flag incl. O-ring
22	P5-22B	1	Indicator cover Blind incl. O-ring
24	P5-24	1	Twist stop
25	P5-25	1	Pilot valve incl. O-rings
26	P5-26	1	Shaft incl. O-rings, screw
27	P5-27	1	Cam locking nut incl. screw
29	P5-29	1	Zero cover
30	P5-30	1	Cover
31	P5-31	1	Mounting adapter, incl screws
32	P5-32	1	Ball bearing
35	P5-xx/xx	1	Identification cover
36	12047N	4	Plug NPT 1/8"
36	12047G	4	Plug 1/8" G
37	P5-Kxx	1	Cam
38-45, 75-80	P5-Screws	1	Screw set P5/E5
46-53	P5-Seal NBR 1		O-ring set P5/E5
81-83, 6 , 67, 70			Nitrile, NBR
46-53	P5-Seal Q	1	O-ring set P5/E5
81-83, 6 , 67, 70			Silicone, Q
54	P5-Sxx	1	Spindle adaptor



## Spare parts, P5/E5

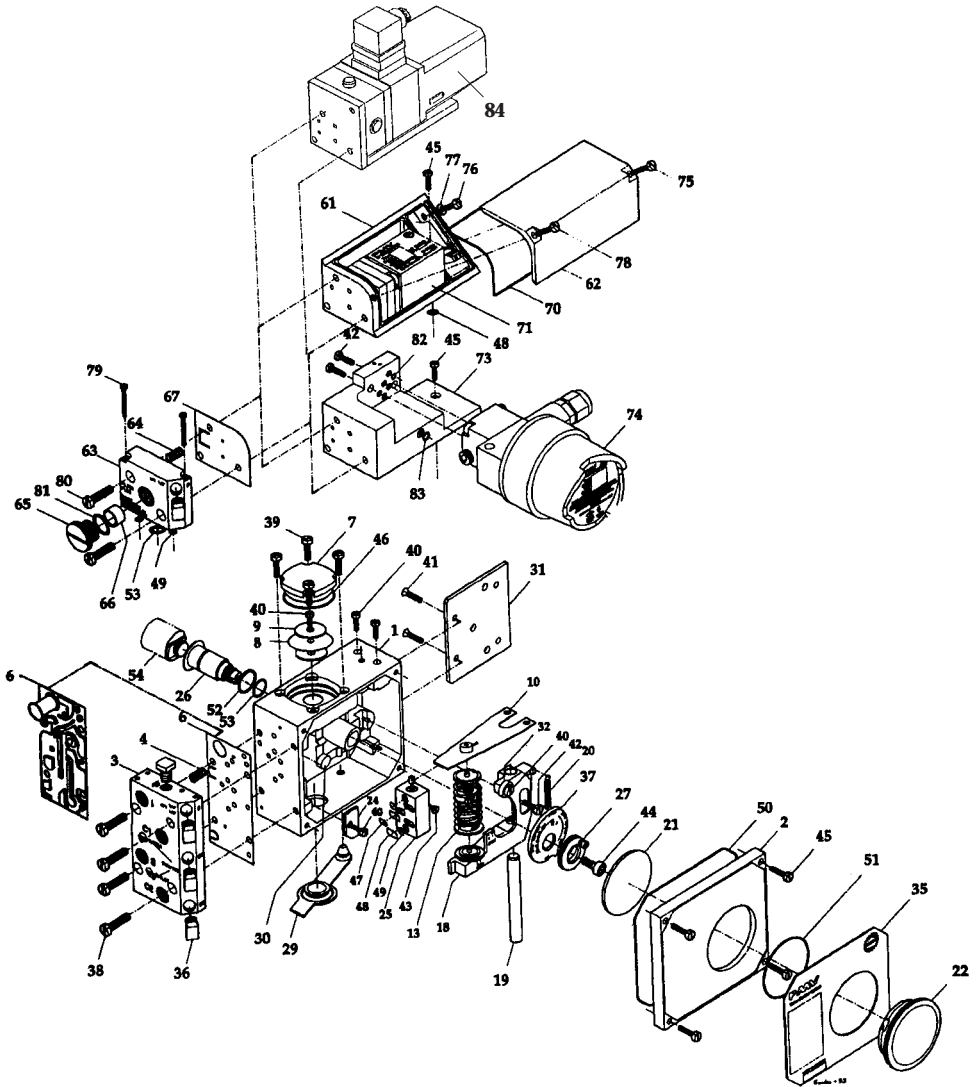

Pos	Part no	Qty	Description
61		1	I/P box
62	E5-2	1	I/P cover incl. screws
63	E5-AS3N	1	I/P nose NPT 1/4" assembly
63	E5-AS3G	1	I/P nose G 1/4" assembly
64	P5-4	1	Relief valve spring
65	E5-5	1	Filter plug incl. Filter 66, O-ring, 81
66	E5-6	1	Filters (5 per package)
67	E5-7	1	Gasket I/P
71	E5-STD	1	I/P converter
73	E5 N-AS 11 E5 G-AS 11	1	Mounting bracket Round I/P incl. screws, O-rings, I/P Nose
74	FU-STD	1	Enclosure incl. I/P converter Std.
74	E5-EX/EU	1	Enclosure incl. I/P converter, flameproof Cenelec
74	E5-EX/US	1	Enclosure incl. I/P converter, Explosionproof FM, CSA
84	E5-FS	1	I/P converter fail in last position incl. bracket



## Cenelec A tex, black label

S: 0F

ABE AUTOMATION

8571830488

09168

19/07/2002



17.3.1 Varieties with inherently safe control units shall not be used (intrinsically safe ones may have been used in type of protection). Unapproved versions of this A tex are immediately voided.

We confirm the correctness of the translation from the German original.  
In the case of exhibition only the German wording shall be valid and binding.

43307 Essen, 28. June 2002  
BVS-Wetzlar A 20010773

Deutsche Montan Technologie GmbH

  
BVS Certification body

  
Head of ATEX services unit

Das ist die ATEX-Zertifizierung  
Die ATEX-Zertifizierung ist eine  
Anforderung an die ATEX-Zertifizierung  
Anforderung an die ATEX-Zertifizierung  
Anforderung an die ATEX-Zertifizierung



Nemko 03ATEX112X Date: 2003-04-30 Page: 2 of 2

## [1] EC-TYPE EXAMINATION CERTIFICATE

(2) Equipment or Protected System Intended for use in Potentially explosive atmospheres Directive 94/9/EC

[3] EC-Type Examination Certificate Number: Nemko 03ATEX112X

[4] Equipment or Protective System: Pneumatic Valve Positioner

[5] Applicant/Manufacturer: PNVV Palmindernis Instrument AB

[6] Address: Korta gatan 9  
S-141 86 Solna  
Sweden

[7] This equipment or protective system and any equivalent variation thereto is specified in the schedule to this certificate and the documents therein referred to.

[8] Nordic AS notified this equipment (EN) in accordance with Article 9 of Council Directive 84/67/EEC of 13 March 1984 certifies that the equipment or protective system has been found to comply with the Essential Health and Safety requirements relating to the design and construction of equipment and protective systems intended for use in potentially explosive atmospheres given in Annex II to the Directive.

The examination and test results are recorded in confidential report no. 200309116

[9] Compliance with the Essential Health and Safety Requirements has been assessed by compliance with:

EN 50014:1997 + A1:1999 + A2:1999

EN 15409:2002

EN 15408:2002

[10] If the sign "X" is placed after the certificate number, it indicates that the equipment or protective system is subject to special conditions for safe use specified in the schedule to this certificate.

[11] This EC-TYPE EXAMINATION CERTIFICATE relates only to the design, examination and test of the specified equipment or protective system in accordance to the directive 94/9/EC.

The marking of the equipment or protective system shall include the following:

[12] The marking of the equipment or protective system shall include the following:

Ex II GD

Oslo, 2003-04-30

R. R. Hjeltnes  
Rolf Hjel  
Certification Department

This certificate may only be reproduced in its entirety and without any change, schedule included.

Postal Address: P.O. Box 73 Blindern  
N-0404 OSLO, NORWAY  
Telephone: +47 22 96 81 30  
Fax: +47 22 96 81 30  
E-mail: info@nemko.no

Postal Address: P.O. Box 73 Blindern  
N-0404 OSLO, NORWAY  
Telephone: +47 22 96 81 30  
Fax: +47 22 96 81 30  
E-mail: info@nemko.no



Nemko 03ATEX112X

## [13] Schedule

[14] EC-TYPE EXAMINATION CERTIFICATE No Nemko 03ATEX112X

[15] Description of Equipment or Protective System

The PNVV positioner is a valve actuator used in either single or double acting applications. The enclosure is made of aluminium and it has a structural flange or dome shaped plastic window for position indicator on the front cover.

Type Designation

P5

Data

Max. Supply Pressure: 1MPa (150PSI)

Ingress Protection Code

IP 66 according to IEC 60529

Type-EX according to NEMA 250

[16] Report No. 200309116

and the list of Schedule Documents P5 Technical File Contents Rev. D. Dated 2003-04-30.

[17] Special Conditions for Safe Use

1. The enclosure is made of aluminium and impact or friction caused by external objects shall be avoided in the application.
2. Rubbing of the windows with dry fabrics shall be avoided when the positioner is used in an IIC atmosphere in order to avoid potentially incentive static discharges.
3. The ambient temperature range for the positioner is: -20°C <T<85°C

[18] Essential Health and Safety Requirements

See item 9

This certificate may only be reproduced in its entirety and without any change, schedule included.

Postal Address: P.O. Box 73 Blindern  
N-0404 OSLO, NORWAY  
Telephone: +47 22 96 81 30  
Fax: +47 22 96 81 30  
E-mail: info@nemko.no

Postal Address: P.O. Box 73 Blindern  
N-0404 OSLO, NORWAY  
Telephone: +47 22 96 81 30  
Fax: +47 22 96 81 30  
E-mail: info@nemko.no





**CSA APPROVED VERSION**

Intrinsically Safe Approval for  
Class I, Groups A, B, C and D with a temperature classification of.

T4A at 85°C  
T6 at 55°C

The unit must be installed according to drawing 96-111.

Division 2 Approval for  
Class I, Division 2, Groups A, B, C and D

These devices are certified as components for use in a suitable enclosure subject to the acceptance of CSA or the Inspection authority having jurisdiction.

**CENELEC APPROVED VERSION**

Intrinsically Safe Approval as  
E Ex ia IIC T4 at 80°C  
T6 at 55°C

Certificate number Ex96D2004X  
Ambient -40°C to 80°C (except for T6)

The following table applies for Is input currents and ambient temperatures

<u>Current Is</u> mA	<u>Maximum Ambient Temperature</u>		
	°C		
	<u>T4</u>	<u>T5</u>	<u>T6</u>
50	80	80	53
60	80	80	47
100	80	80	
120	80	75	
150	80	57	

The unit must be installed alone in a metallic enclosure with  
i) a magnesium content of less than 6% by weight.  
and ii) a minimum IP rating of IP20

The distance from the terminals to any earthed metal must be greater than 3mm and the circuit must be capable of withstanding a voltage of 500 Vrms to case or earth for one minute.

The unit must be installed according to drawing 96-108.

**WARNING!**

These instruments must be installed in accordance with local and national codes of practice, especially for hazardous area installations. The instruments are fully isolated from ground and therefore grounding is unnecessary for functional purposes. However, grounding may be necessary to conform to installation codes.

**HAZARDOUS AREA VERSIONS**

The instrument is available in versions suitable for use in hazardous areas. The hazardous area versions carry information on their certification on a special label. This gives an indication to the correct areas of use.

**WARNING!**

Installation of any hazardous area equipment should be made in accordance with hazardous area installation codes and also of course to the installation to the installation and operating instructions provided. The manufacturer cannot be held responsible for incorrect installation or any customer modifications to, or repair of, a certified instrument as this may invalidate the certified design. If a certified instrument should fail, no attempt should be made by the user to effect repair. The unit should be returned to the factory.

**FM APPROVED VERSION**

Intrinsically Safe Approval for  
Class I, Division 1, Groups A B C D hazardous locations with a temperature classification of.

T4 ambient 40°C  
T3B ambient 70°C  
T3A ambient 85°C  
T6 ambient 55°C

These units must be installed in accordance with:

- The National Electrical Code (ANSI/NFPA 70) and ANSI/ISA RP 12.6, "Installation of Intrinsically Safe Instrument Systems in Class 1 Hazardous (Classified) Locations".
- The installation drawing 96-114.
- The Installation and Operating Instructions provided with each unit.
- The I/P shall be installed in a properly grounded metal enclosure.

## FM White label

96-114, ISSUE "C" - FM IS SYSTEM

DO NOT SCALE DRAWING, IF IN DOUBT ASK.

HAZARDOUS LOCATION

NON-HAZARDOUS LOCATION

CLASS DIVISION 1 GROUPS A,B,C AND D

**NON-HAZARDOUS LOCATION**  
UNSPECIFIED EXCEPT THAT IT MUST NOT BE SUPPLIED FROM NOR CONTAIN UNDER NORMAL OR ABNORMAL CONDITIONS A SOURCE OF POTENTIAL WITH RESPECT TO EARTH IN EXCESS OF 250 VOLTS RMS OR 250V DC

**SAFETY BARRIER.**  
SEE NOTE 3.

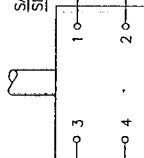

SEE NOTE 2

OPTIONAL SCREEN

**FM**  
**CERTIFIED PRODUCT**  
No modifications are permitted without reference to FMRC.

FOR ES-IS/US WITH T CODE	
T4 at 40°C	T6 at 55°C
T3B at 70°C	Vmax = 28V dc
T3A at 85°C	Imax = 46.7mA dc
Vmax = 30V dc	CI = 0.4µF
Imax = 96mA dc	LI = 3.7mH
CI = 0.4µF	
LI = 3.7mH	

3. ANY POSITIVE POLARITY SAFETY BARRIER APPROVED BY FMRC FOR GROUPS A,B,C AND D WHOSE OUTPUT PARAMETERS ARE :-

FOR ES-IS/US WITH T CODE	
T4 at 40°C	T6 at 55°C
T3B at 70°C	Voc or Vt ≥ 12V and ≤ 28V
T3A at 85°C	Isc or It ≤ 46.7mA
Voc or Vt ≥ 12V and ≤ 30V	Pmax ≤ 0.33W
Isc or It ≤ 96mA	
Pmax ≤ 0.8W	
eg. MIL 728	
P & F 7428/Ex	

THE OUTPUT CURRENT MUST BE LIMITED BY A RESISTOR R SUCH THAT  $R \geq V_{oc} / I_{sc}$

### NOTES

1. THE ELECTRICAL CIRCUIT IN THE HAZARDOUS AREA MUST BE CAPABLE OF WITHSTANDING AN A.C. TEST VOLTAGE OF 500 VOLTS R.M.S. TO EARTH OR FRAME OF THE APPARATUS FOR 1 MINUTE.

2. CABLE CAPACITANCE AND INDUCTANCE PLUS THE I.S. APPARATUS UNPROTECTED CAPACITANCE (Ct) AND INDUCTANCE (Lt) MUST NOT EXCEED THE ALLOWED CAPACITANCE (Cg) AND INDUCTANCE (Lg) INDICATED ON THE ASSOCIATED APPARATUS.

4. THE INSTALLATION INCLUDING THE BARRIER EARTHING ARRANGEMENTS MUST COMPLY WITH THE INSTALLATION REQUIREMENTS OF THE COUNTRY OF USE ie ANSI/ISA RP12.0 (INSTALLATION OF INSTRUMENTALLY SAFE SYSTEMS FOR HAZARDOUS (CLASSIFIED) LOCATIONS) AND IPEC NATIONAL ELECTRICAL CODE. INSTALLATION MUST BE IN ACCORDANCE WITH THE MANUFACTURERS GUIDELINES.

UNSPECIFIED TOLERANCES

X 40.5mm x XX 40.15mm  
X 20.2mm x XX 20.1mm  
X 10.1mm x XX 10.05mm  
EDGES TO 0.25 MAX

UNLESS OTHERWISE STATED

ISS	NO.	DATE	ISS	NO.	DATE	WHERE USED	DRAWN	APPROVED	FINISH
0	0001	18-03-98							
1	0001	18-03-98							
2	0001	18-03-98							
3	0001	18-03-98							
4	0001	18-03-98							



WATSON SMITH LTD  
6005 CHALMERS ST.  
MILTON KEYNES MK11 2JY  
TEL: 01295 235 757

This document is confidential. Comments to be sent to: [comments@wsm.co.uk](mailto:comments@wsm.co.uk)  
© 1996 Watson Smith Ltd

ISS	NO.	DATE	ISS	NO.	DATE	WHERE USED	DRAWN	APPROVED	FINISH
0	0001	18-03-98							
1	0001	18-03-98							
2	0001	18-03-98							
3	0001	18-03-98							
4	0001	18-03-98							

ISS	NO.	DATE	ISS	NO.	DATE	WHERE USED	DRAWN	APPROVED	FINISH
0	0001	18-03-98							
1	0001	18-03-98							
2	0001	18-03-98							
3	0001	18-03-98							
4	0001	18-03-98							

ISS	NO.	DATE	ISS	NO.	DATE	WHERE USED	DRAWN	APPROVED	FINISH
0	0001	18-03-98							
1	0001	18-03-98							
2	0001	18-03-98							
3	0001	18-03-98							
4	0001	18-03-98							

ISS	NO.	DATE	ISS	NO.	DATE	WHERE USED	DRAWN	APPROVED	FINISH
0	0001	18-03-98							
1	0001	18-03-98							
2	0001	18-03-98							
3	0001	18-03-98							
4	0001	18-03-98							

ISS	NO.	DATE	ISS	NO.	DATE	WHERE USED	DRAWN	APPROVED	FINISH
0	0001	18-03-98							
1	0001	18-03-98							
2	0001	18-03-98							
3	0001	18-03-98							
4	0001	18-03-98							

ISS	NO.	DATE	ISS	NO.	DATE	WHERE USED	DRAWN	APPROVED	FINISH
0	0001	18-03-98							
1	0001	18-03-98							
2	0001	18-03-98							
3	0001	18-03-98							
4	0001	18-03-98							

ISS	NO.	DATE	ISS	NO.	DATE	WHERE USED	DRAWN	APPROVED	FINISH
0	0001	18-03-98							
1	0001	18-03-98							
2	0001	18-03-98							
3	0001	18-03-98							
4	0001	18-03-98							

ISS	NO.	DATE	ISS	NO.	DATE	WHERE USED	DRAWN	APPROVED	FINISH
0	0001	18-03-98							
1	0001	18-03-98							
2	0001	18-03-98							
3	0001	18-03-98							
4	0001	18-03-98							

ISS	NO.	DATE	ISS	NO.	DATE	WHERE USED	DRAWN	APPROVED	FINISH
0	0001	18-03-98							
1	0001	18-03-98							
2	0001	18-03-98							
3	0001	18-03-98							
4	0001	18-03-98							

ISS	NO.	DATE	ISS	NO.	DATE	WHERE USED	DRAWN	APPROVED	FINISH
0	0001	18-03-98							
1	0001	18-03-98							
2	0001	18-03-98							
3	0001	18-03-98							
4	0001	18-03-98							

ISS	NO.	DATE	ISS	NO.	DATE	WHERE USED	DRAWN	APPROVED	FINISH
0	0001	18-03-98							
1	0001	18-03-98							
2	0001	18-03-98							
3	0001	18-03-98							
4	0001	18-03-98							

ISS	NO.	DATE	ISS	NO.	DATE	WHERE USED	DRAWN	APPROVED	FINISH
0	0001	18-03-98							
1	0001	18-03-98							
2	0001	18-03-98							
3	0001	18-03-98							
4	0001	18-03-98							

ISS	NO.	DATE	ISS	NO.	DATE	WHERE USED	DRAWN	APPROVED	FINISH
0	0001	18-03-98							
1	0001	18-03-98							
2	0001	18-03-98							
3	0001	18-03-98							
4	0001	18-03-98							

ISS	NO.	DATE	ISS	NO.	DATE	WHERE USED	DRAWN	APPROVED	FINISH
0	0001	18-03-98							
1	0001	18-03-98							
2	0001	18-03-98							
3	0001	18-03-98							
4	0001	18-03-98							

ISS	NO.	DATE	ISS	NO.	DATE	WHERE USED	DRAWN	APPROVED	FINISH
0	0001	18-03-98							
1	0001	18-03-98							
2	0001	18-03-98							
3	0001	18-03-98							
4	0001	18-03-98							

ISS	NO.	DATE	ISS	NO.	DATE	WHERE USED	DRAWN	APPROVED	FINISH
0	0001	18-03-98							
1	0001	18-03-98							
2	0001	18-03-98							
3	0001	18-03-98							
4	0001	18-03-98							

ISS	NO.	DATE	ISS	NO.	DATE	WHERE USED	DRAWN	APPROVED	FINISH
0	0001	18-03-98							
1	0001	18-03-98							
2	0001	18-03-98							
3	0001	18-03-98							
4	0001	18-03-98							

ISS	NO.	DATE	ISS	NO.	DATE	WHERE USED	DRAWN	APPROVED	FINISH
0	0001	18-03-98							
1	0001	18-03-98							
2	0001	18-03-98							
3	0001	18-03-98							
4	0001	18-03-98							

ISS	NO.	DATE	ISS	NO.	DATE	WHERE USED	DRAWN	APPROVED	FINISH
0	0001	18-03-98							
1	0001	18-03-98							
2	0001	18-03-98							
3	0001	18-03-98							
4	0001	18-03-98							

