

TYPICAL AC WIRING SCHEMATIC

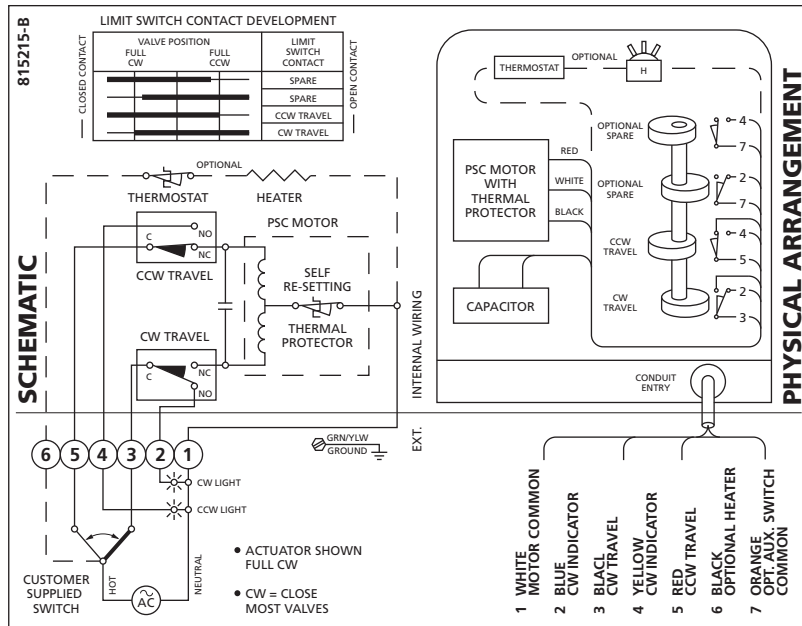

TYPICAL DC WIRING SCHEMATIC

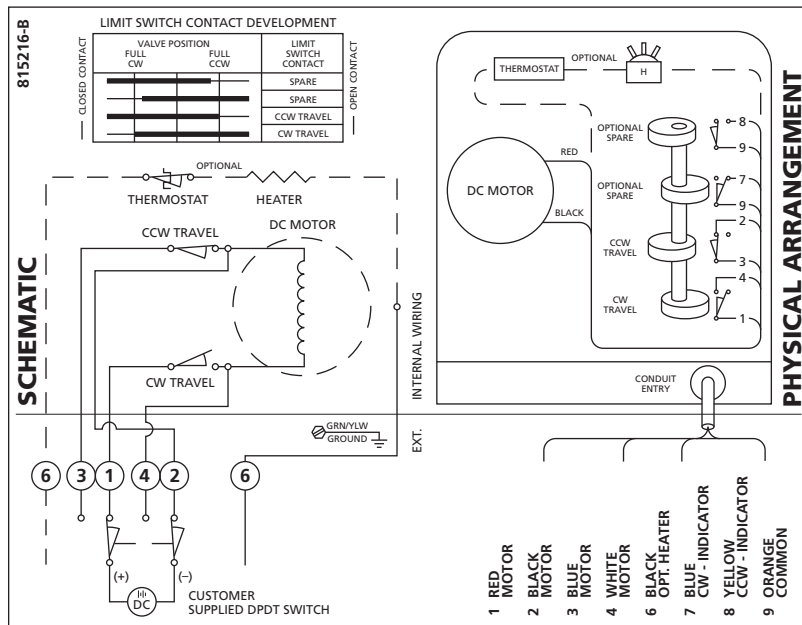

EV Electric Actuator

Use & Care Manual

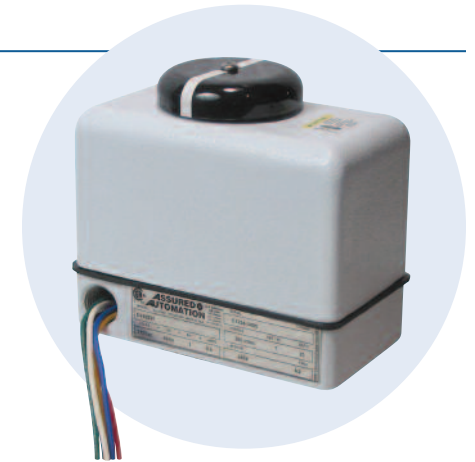

1. INTRODUCTION

The EV electric actuator by Assured Automation brings the latest technology in valve actuation. The EV series delivers 125 and 300 in-lbs of torque in a completely enclosed compact package. The unit is designed for NEMA 4, and 4X corrosion protection.

2. INSTALLATION

Installing the EV series actuator is simple and straightforward. The principle of operation requires a signal (voltage source) to be supplied, which tells the unit to drive to the open position or to drive to the close position. Note that separate signals must be sent to tell the unit which direction to rotate. The AC unit is equipped with a Permanent Split Capacitor gearmotor. This means that there are two windings (one for each direction of travel). The Capacitor helps the motor start rotating and is specially sized for actuator requirements. The capacitor is wired across both windings of the motor and is energized in both directions.

1. Before applying power to the unit and before mounting it onto a valve, make sure the unit is able to rotate freely. If the unit is equipped with a manual override use a wrench to rotate it back and forth.

2. Also make sure manually that the valve rotates freely. Remove any physical valve stops if possible to prevent valve damage from stalling the motor.
3. Mount the actuator onto the valve such that it is in the same operating sequence as the valve (i.e. valve open – actuator open).
4. Carefully align the output shaft of the actuator with the valve or damper stem. Mis-alignment will cause pre-mature failure. Tighten the bolts to the actuator evenly.
5. Position the valve/actuator assembly in the mid-stroke position manually before applying power to prevent damage.
6. Connect to a power supply as per the wiring instructions. The wiring instructions are attached to the inside

of the cover. Almost all applications require some type of customer-supplied switch used to direct the rotation of the unit. The wires extending from the unit are as marked on the wiring diagram.

Caution: Keep cover closed while circuits are energized.

7. Power to the unit should be fused with a 5amp slow blow fuse. All wiring is to be completed in accordance to National and Local electric codes.
8. Once wired, the unit should be rotated electrically to verify directional operation.

Caution: Some valves and dampers have manual stops; remove if appropriate or adjust actuator travel switches to operate within those stops.

3. OPERATION

Limit Switches

The limit switches are factory set for 90° rotation. They can be adjusted to give as much as 270° or as little as 30° operation. Simply use a 3/32" hex wrench to loosen the set screw in the cam and adjust its trip position. The switches are the SPDT type which means that they have an extra contact connected when at the end of travel that can be used to electrically indicate position.

All of the switches are rated 15amp at 115Vac. Two extra switch contacts may be ordered as an option (dry contacts). These switches can be used for indication or to control other devices.

Caution: Turn manual override shaft slowly to allow motor gears to backdrive. Do not force.

Manual Override

The manual override extends out through the top of the unit and also indicates the position. Once the Position Indicator is removed a 3/8" wrench can be applied to flats on the top of the unit to manually drive the valve to the desired position. Note that if the unit is rotated out of its normal operating range the switches will have to be adjusted to set the end of travel. Be careful not to turn the manual override too fast as the motor is also driven and can be damaged in this fashion. The manual override is connected directly to the output and turns in the same direction as the output. A quarter turn of the M.O. rotates the output 90°.

Position Indicator

A position indicator may be ordered as an option. It is made of bright colored polycarbonate. The indicator will have to be removed before manually operating the unit.

AC Motors

The motor is a permanent split capacitor type (PSC). It has an automatically re-setting thermal protector. This means that if the unit is excessively stroked in an elevated temperature environment, the unit will shut down. The thermal switch buried in the windings of the motor opens up the current flow through the windings preventing it from burning. After the unit is left to cool the thermal switch will automatically close allowing operation again. The length of time the unit can run continuously without thermal trip is known as its duty cycle and depends on the ambient temperature. All Assured Automation PSC motors are sized specifically for valve automation and contain heavy duty ball bearings for long motor life. The motors are rated for 50 or 60Hz. However, the speed ratings are based on 60Hz operation. 50Hz supply increases the cycle time by approximately 1.2 times and reduces the duty cycle roughly 25%.

Housing

The cover and base have a thick protective polyester paint to guard them from corrosion. The base gasket, which seals the cover, is secured in place to prevent its loss. The cover screw is captive to also prevent its loss upon removal.

Conduit Entries

There is an option available to allow a 2nd 1/2-14NPT conduit entry. This can be used to separate any signal sources from power supplies. Note that the wires may be sealed to prevent water and other liquids from entering the unit through the conduit entries.

4. MAINTENANCE

There are no special requirements for maintaining your EV electric actuator. The gear train has been permanently lubricated for a long life. If it should become necessary to re-fill the lubrication it is recommended that the unit be filled with multi-purpose grease. If possible use Mobiltemp® SHC32 or equivalent. All the drive gears in the unit are made of heat treated alloy steel that can withstand stall torque conditions. The unit should be cycled periodically to verify its operation. If the unit will be stored for more than a year please refer to bulletin B00042 Long Term Storage and Care of Electric Actuators.

5. TROUBLE SHOOTING

1. PROBLEM: There is power to the unit but it does not respond.

- 1.1 Verify that the correct voltage has been applied according to the ratings listed on the nameplate.
- 1.2 Check the wiring to verify it against the wiring schematic.
- 1.3 Check the limit switches to see if they are tripped and operating in the correct range.

2. PROBLEM: Power is getting to the motor but it merely hums.

- 2.1 Check to make sure that the proper voltage is applied and that all of the wiring connections are tight.
- 2.2 Check to see that the unit is properly grounded.
- 2.3 Check to see that the CW and CCW switches are not being powered at the same time. This will happen if the customer directional control switch is not wired correctly.

3. PROBLEM: The actuator performs erratically.

- 3.1 Check to see that the actuator is not stalling. Remove the actuator from the valve and verify the freeness of the valve operation.
- 3.2 Check to see that the valve torque requirements are less than the rated torque output of the actuator.
- 3.3 Check the ambient temperature rating. The PSC motors are equipped with thermal protectors which cut power to the motor if excessively cycled. High temperature ambients and cycle frequencies may heat up the motor causing the thermal protector to automatically turn off power to the motor. Simply allow the unit to cool and it will automatically re-set.

6. TECHNICAL ASSISTANCE

Assured Automation will be more than happy to provide technical assistance should it become necessary. Please have the following available when calling for assistance:

1. Actuator model number.
2. Actuator serial number.
3. Input signal being used.
4. Valve application.